

An Alternative Approach to a Wide-Band NVIS Antenna System

L. B. Cebik, W4RNL
1434 High Mesa Drive
Knoxville, TN 37938-4443
e-mail: cebik@cebik.com

Some HF services require the use of a wide span of HF frequencies and high-speed agility to change frequencies according to propagation and other conditions. In addition, they require the use of Near Vertical Incidence Skywave (NVIS) modes of communications in which transmitted and received signals refract or reflect from ionospheric layers at or near the zenith angle. When we combine all of these requirements, current antenna systems tend to fall short of effectively meeting the need. Meeting all of the requirements, including the NVIS provision, requires a complete re-thinking of the antenna system as a whole.

These notes will outline an alternative approach to meeting the needs for wide-band NVIS with a high level of frequency agility.

The Shortcomings of Current Wide-Band Antenna Systems

The common feature of current wide-band antenna systems is a focus upon the impedance of the antenna itself. In general, the antenna design attempts to provide a nearly constant feedpoint impedance from some low frequency to some high frequency. Following current government spectrum usage, we shall define this range as roughly 2 MHz to about 30 MHz.

1. *The Broadband Vertical Antenna*: One popular antenna choice for broad band service is the vertical antenna. With proper design, it is possible to achieve multi-octave coverage.

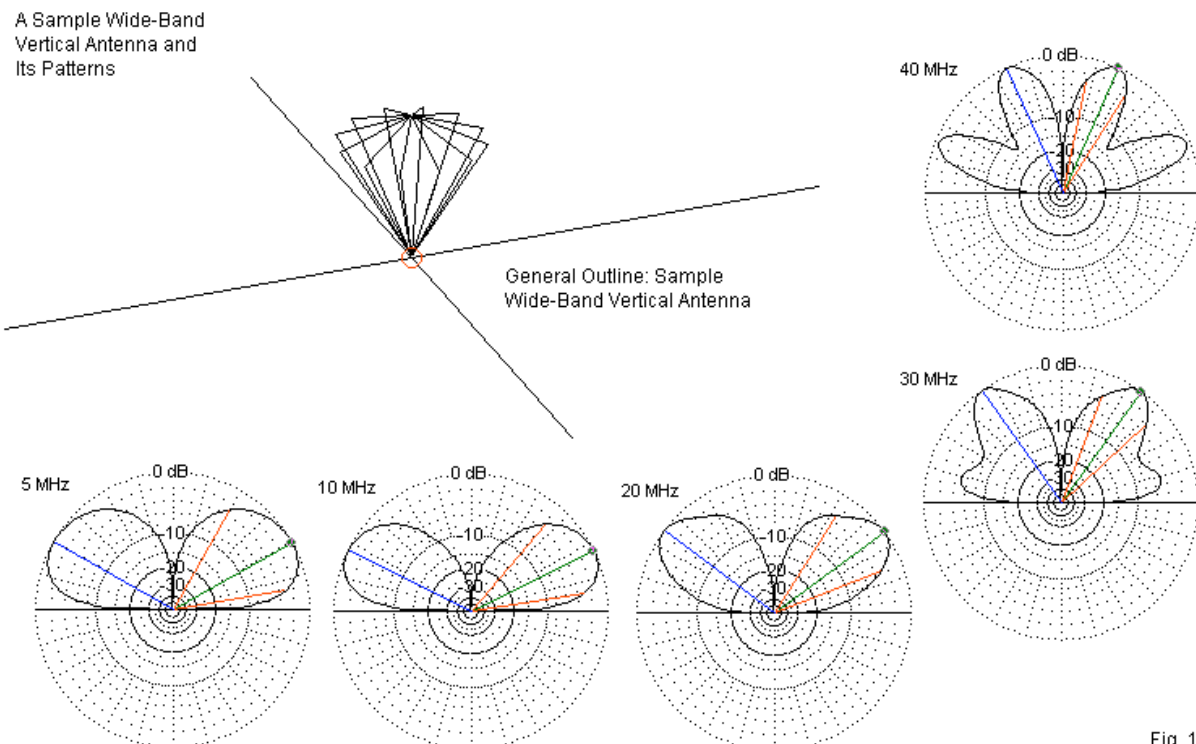

Fig. 1

Fig. 1 shows the outlines of one such system. The original array was designed for about 5 MHz upward. It consists of 12 vertical wires forming a closed cone with 4 elevated radials at the base. The figure includes sample elevation patterns for 5 through 40 MHz. Each elevation pattern reflects the performance characteristics in **Table 1**, as modeled in NEC-4 over average ground (conductivity 0.005 S/m, relative permittivity 13).

Table 1. Sample Broadband Vertical Antenna Performance

Frequency MHz	Gain dBi	TO Angle degrees	Feedpoint Impedance R +/- jX Ω	200- Ω SWR
5	-4.65	29	149 - j 124	2.14
10	-0.63	26	247 - j 94	1.60
20	0.87	36	244 - j 30	1.27
30	2.83	54	223 - j 20	1.16
40	2.41	66	245 - j 10	1.23

The antenna is quite remarkable in its broadband impedance performance. Over a nearly 8:1 frequency range, it maintains an SWR at or below 2:1 relative to 200 Ω . A simple 4:1 balun reduces the impedance to the near-50- Ω range for easy feeding with a simple coaxial cable.

The original antenna is about 30' tall with 4 100' radials. To reduce the lower frequency limit to about 2 MHz, we must increase all dimensions by a factor of 2.5, yielding an antenna about 75' tall with 4 250' radials. **Fig. 2** shows the 200- Ω SWR curve of the scaled-up structure.

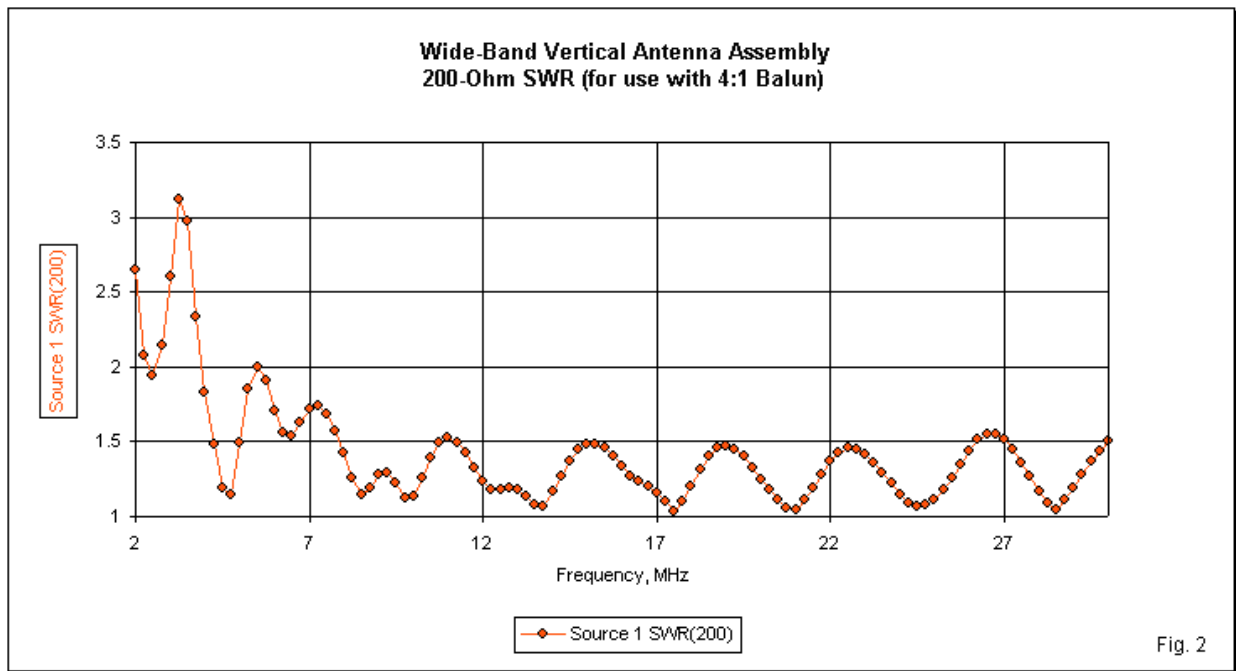

Fig. 2

The antenna system is an excellent example of an antenna with highly consistent feedpoint performance, but relatively poor consistency of pattern development. The sample patterns illustrate that once a vertical antenna exceeds about $5/8 \lambda$, it develops relatively thin elevation lobes with null regions between them. The position of the elevation lobes varies with changing frequency. **Fig. 3** tracks the maximum gain and TO (take-off) angle or the elevation angle of

maximum radiation. While exhibiting periodic properties that might be useful in some circumstances, the array patterns vary too widely for reliable skip communications of any sort.

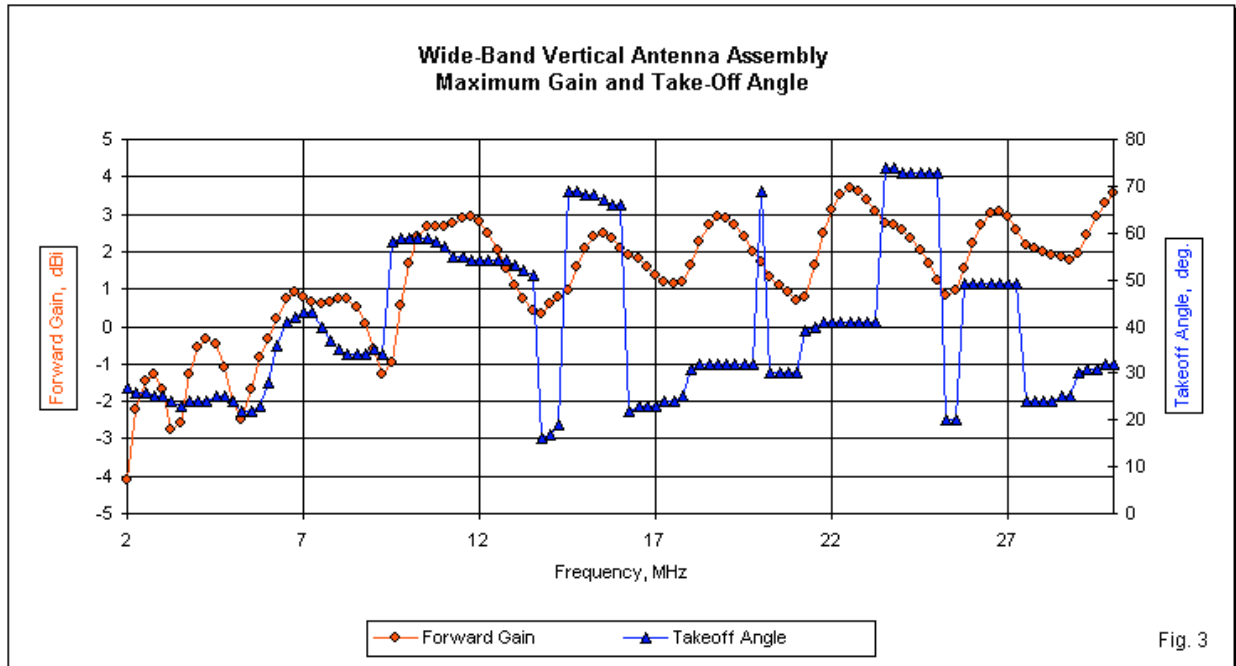

Fig. 3

Like all vertical antennas, the broadband antenna used as a sample here exhibits a null for angles at or near the zenith. This holds true not only in the patterns in **Fig. 1**, but for all patterns of all vertical antennas. As a result, the vertical array, whatever its feedpoint impedance characteristics, is an inappropriate antenna for NVIS-mode communications.

2. *The Wide-Band Terminated Folded Dipole:* In many applications, the need for wide-band communications in the HF range is assigned to a wide-band terminated folded dipole. This type of antenna has many variations, using from 1 to 3 main horizontal wires, along with 1 or more terminating resistors. The sample version that we shall explore uses the folded-dipole configuration, although the presence of a terminating resistor positioned opposite the feedpoint precludes operation in the normal folded dipole mode. (A true folded dipole is a combination of impedance transformer and radiator, with both transmission-line and radiation currents along the wires. The terminated version lacks the transmission-line currents.)

Terminated folded dipoles and similar wide-band antennas use high-value non-inductive terminating resistors or a means of simulating such resistors. For the present sample (about 164' from end to end), the required value is about 820 Ω . Alternative to fabricating such a resistor is the use of a 50- Ω resistor along with a 16:1 balun. Since the feedpoint impedance will have a center value like that of the terminating resistor, a similar balun is used at the wire feedpoint to effect a match with 50- Ω coaxial cable.

Fig. 4 shows the general outline of the terminated folded dipole, along with selected elevation and azimuth patterns. The subject antenna is 75' above average ground for effective radiation at the lowest frequency, 2 MHz. The performance associated with each pattern appears in **Table 2**.

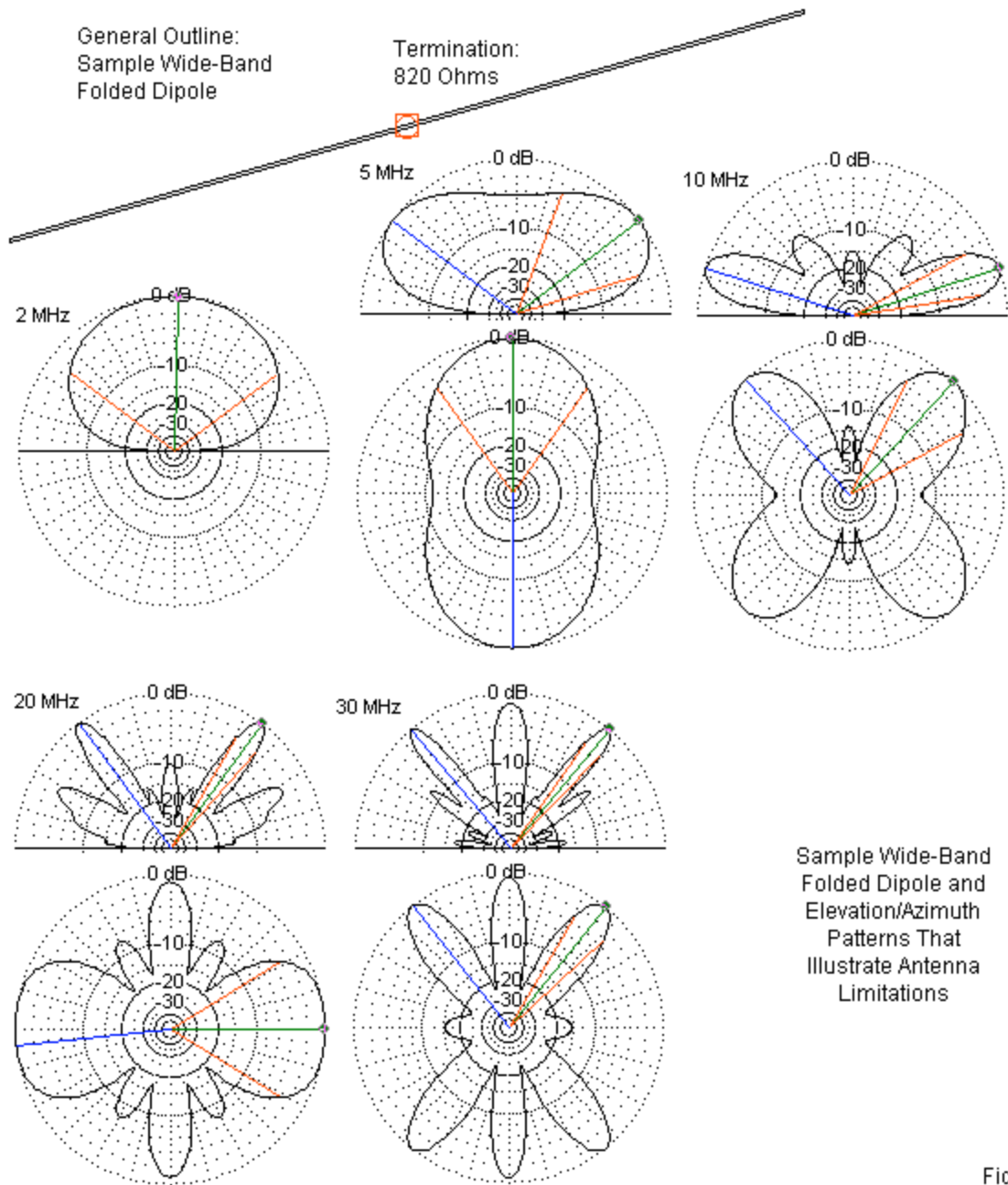

Fig. 4

Table 2. Sample Broadband Terminated Folded Dipole Antenna Performance

Frequency MHz	Gain dBi	TO Angle degrees	Feedpoint Impedance R +/- jX Ω	200- Ω SWR
2	-6.32	90	1100 + j 2	1.33
5	1.99	37	700 - j 390	1.71
10	4.99	18	1200 - j 620	2.04
20	2.58	53	820 + j 280	1.41
30	2.46	50	490 - j 80	1.71

As any horizontal wire grows longer than 1.25λ , the pattern breaks into multiple lobes, regardless of the presence or absence of a terminating resistor. Hence, above about 7.5 MHz, the 164' terminated folded dipole shows multiple-lobe patterns rather than the typical dipole bi-directional pattern. As well, the strongest elevation angle may show high variability. The termination reduces gain by 5-6 dB relative to a non-terminated wire antenna of the same length for all lengths greater than about $\frac{1}{2} \lambda$. (A length of $\frac{1}{2} \lambda$ is the "knee" of the terminated antenna performance curve. Below the knee, the impedance is closer to the target value due to increased dissipation of energy in the terminating resistor. However, gain decreases relative to a non-terminated wire at an ever-increasing rate.)

The result is an antenna that is not especially reliable for general HF communications and certainly not usable for NVIS communications. Despite these pattern failures, the antenna shows a remarkably consistent SWR relative to a target design value. **Fig. 5** shows the 820- Ω SWR value for the sample antenna. Coaxial cable line losses and balun losses for normal installations tend to hold the value measured at the operating position at or below 2:1.

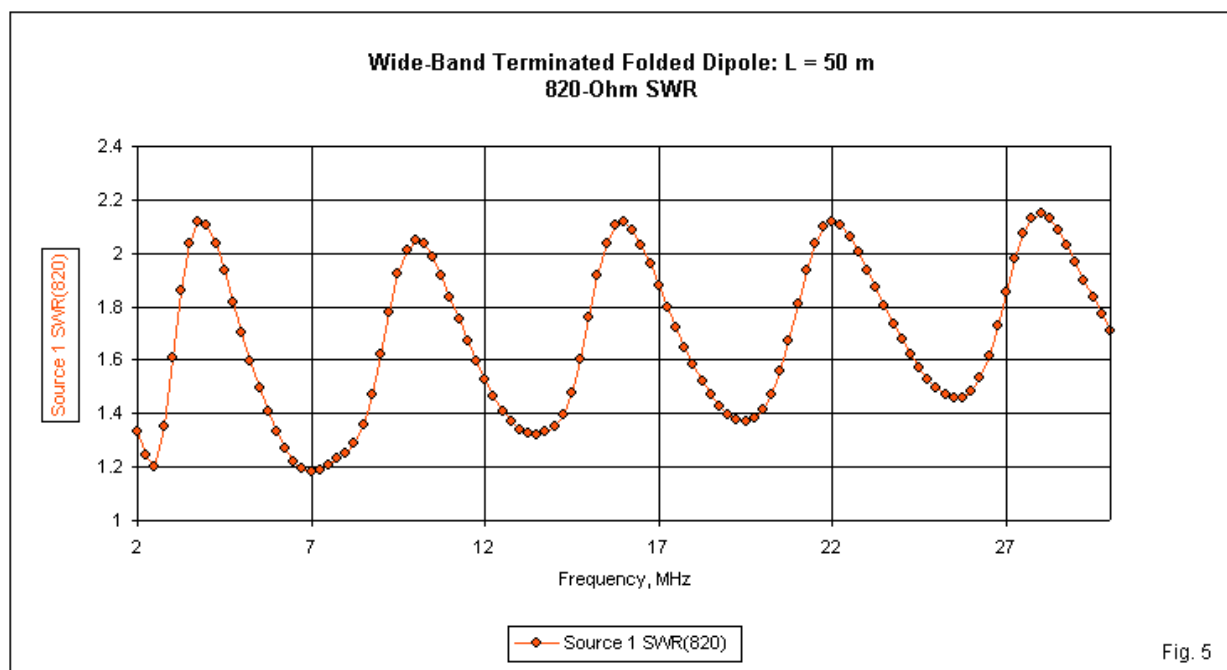

Fig. 5

Some Background Notes on NVIS Antennas

Virtually any horizontal antenna may serve at least as a narrow-bandwidth NVIS antenna if brought close enough to the ground. Therefore, the most fundamental NVIS antenna--widely used by amateur radio operators--is the simple dipole. Research suggests that the ideal height above ground for virtually any antenna in NVIS service is between 0.15λ and 0.20λ . Under these conditions, the antenna exhibits maximum gain at the zenith angle.

Many NVIS antennas specify the placement of a second parasitic wire below the fed wire. The recommended spacing varies, but the practice is marginal at best. Research has shown that NVIS antennas tend to operate similarly to plane-reflector arrays, where the ground acts as the plane reflector. (Plane reflector arrays are widely used at VHF and UHF for such services as television and FM repeater communications.) If one is to place a reflector below the fed wire, it must have outer horizontal dimensions that extend about $\frac{1}{2} \lambda$ (at the operating frequency)

beyond the limits of the fed-portion of the antenna. Plane reflectors operate on principles derivable from optical principles. As a result, every increase in gain is accompanied by the corresponding decrease in beamwidth in one or both (X and/or Y) coordinates. For many NVIS applications, a beamwidth of about 90° between half-power points is necessary to effect adequate coverage. For most such wide-beamwidth applications, the angles in both the X and Y coordinate axes should be as close to identical as possible.

Some antenna configurations that are desirable for narrow-band operations are not suitable for wide-band operations. For example, the square or quad loop shows gain at the zenith angle over a dipole when both are at the same height. However, a quad loop produces broadside radiation to the plane of the loop only when the loop is close to 1 λ in circumference. As we move away from that length, radiation is mostly from the loop edges, a useful low-angle skip property, but not a useful property for NVIS communications.

A simple dipole will yield NVIS-compatible patterns over a considerable frequency range. **Fig. 6** shows the patterns for a center-fed doublet over a 2:1 frequency range when the antenna height is 0.2 λ at the lowest frequency and the antenna length is ½ λ at the same frequency. The data for each displayed pattern appears in **Table 3**.

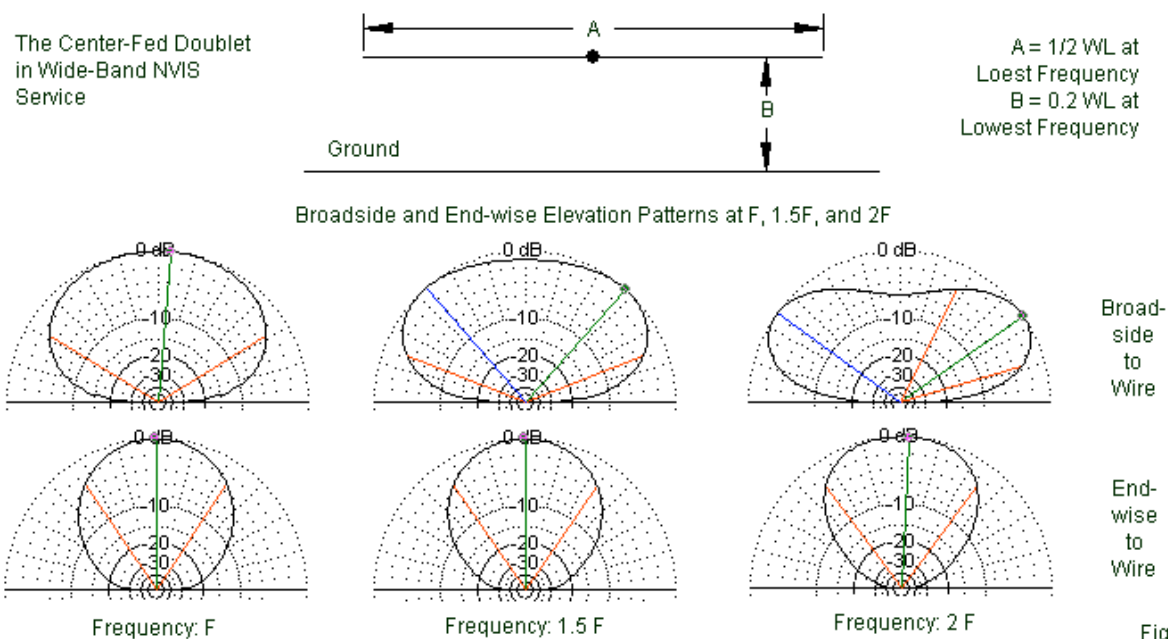

Fig. 6

Table 3. Doublet Performance over a 2:1 Frequency Range

Frequency MHz	Gain dBi	Broadside Beamwidth Degrees	Wire-End Beamwidth degrees
F (3.5)	6.45	118	68
1.5F (5.25)	6.52	137	69
2F (7.0)	8.06	47 (x2)	73

With some height reduction, the pattern for 7 MHz can be brought to NVIS standards of showing maximum gain at the zenith angle. However, the simple dipole suffers a more fundamental flaw

as a broadband NVIS antenna: the beamwidth broadside to the wire is always considerably greater than the beamwidth along the wire axis (called "wire-end beamwidth" in the table). As a result, the dipole is not ideal for NVIS work.

An Alternative Approach to Broadband NVIS Antennas for 2 - 30 MHz

The alternative approach to wide-band NVIS antenna systems changes the priority of primary properties of the systems. The foremost criteria for the NVIS antenna system is pattern shape to ensure that the system provides adequate coverage of the overhead region. Ideally, the system should focus primary energy (and receive sensitivity) directly over head, with half-power point at least 45° away from the zenith in any azimuth direction (90° total beamwidth).

The wide and relatively uniform beamwidth of the antenna system comes at a cost in gain. Very narrow-beam systems are capable of up to about 10-dBi gain directly overhead, but with beamwidths under 40°. Gain values in the range of 2 to 4 dBi are available in broader beamwidths. However, the antenna will require a different shape than the linear dipole to ensure that the half-power points are relatively uniform both broadside and end-wise to the wire antenna.

The antenna system itself should consist of relatively simple antenna shapes to ensure durability in varied climates and to achieve economy of construction and maintenance. For this reason, the system should consist of the fewest wires feasible and the fewest and smallest support structures.

Simple wire antennas are capable of about a 2:1 frequency range for maintaining requisite pattern shapes for effective NVIS use. In such use, the feedpoint impedance will vary greatly from F to $2 F$. Traditional treatment of such antennas has been to use various techniques to develop a uniform feedpoint impedance, at the expense of pattern shape, gain, or overall structural complexity. However, using a simple shape over a 2:1 frequency range allows coverage from 1.875 MHz to 30 MHz with four simple antennas. The antennas are near scale versions of each other, resulting in a single long antenna for the lowest range and successively shorter antennas for the upper ranges. The shorter antennas, of course, come with associated reductions in the support heights. Since true NVIS activity is confined to the region below about 12 MHz, one can use 3 of the 4 antennas in this sequence, although the fourth appears to complete full HF coverage.

The matching requirements of the antenna become an exercise in electronic control via mechanisms and techniques already in use. As we shall see, the requisite matching requirements for true frequency agility in real time will require a change in thinking about matching network construction. However, the resulting system will place complexities within closed and weatherproof casings, separated from the effects of the local station climate.

1. *Antenna Configuration:* To effect a nearly circular pattern for wide-band NVIS antennas, we require the inverted-V configuration, with the ends of the antenna close to ground. **Fig. 7** shows the general outline of the NVIS inverted V, with a guide to the key dimensions. See **Table 4** for the dimensions of the individual antennas that cover the HF range as defined above. As well note the simplicity of the support system. It requires a single center support, with two short supports for the wire ends.

General Outline for a Wide-Band NVIS Inverted-V Antenna

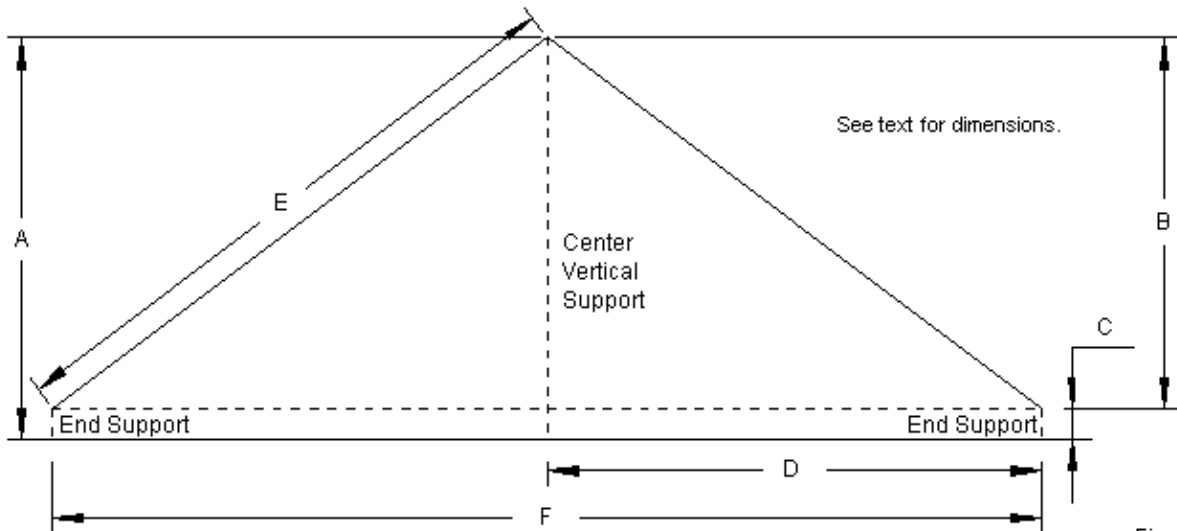

Fig. 7

Table 4. Dimensions of Inverted-V Antennas in NVIS Service: All dimensions in feet

Frequency Range MHz	A Total height above ground	B Antenna height	C Wire end height	D Leg length horizontally	E Leg length diagonally	F Total horizontal span
1.875 - 3.75	75	70	5	105	126	210
3.75 - 7.5	42.5	40	2.5	50	64	100
7.5 - 15	21.25	20	1.25	25	32	50
15 - 30	11	10	1	12.5	16	25

The entire antenna set requires only 1 to 2 center supports that might need 3-legged tower-type construction. The smaller central supports for the upper 2 frequency segments may use single poles as center supports. The towers can also be used to support a variety of fixed or rotatable antennas in the HF through UHF ranges. For minimal interaction, the antennas for adjacent frequency segments should be at right angles to each other. Under these conditions, all 4 antennas should fit within a square no larger than 210' on a side--with considerable (usable) empty space within it. The operating station will expand the required space only slightly.

Note that the antennas are not perfectly scaled on the largest member of the group. Ground effects change with frequency, occasioning some change of shape for pattern development according to specification. The inverted-V antenna has a vertical component and is subject to ground losses and changes in the optimal height above ground to achieve the desired pattern shape. The effects are relatively small and may be neglected if standardization of equipment is desired for multiple installations. Otherwise, one may optimize via NEC-4 models the optimal shape for the inverted-V for individual sites, using the applicable ground constants. The overall height of the largest antenna in the group will not change, so larger structures will remain uniform for all potential installations.

2. *Antenna Performance:* The theory of antenna operation is straightforward. A dipole set at near-optimal NVIS height produces an oval pattern that is wider broadside to the antenna than in the plane of the wire. Bending the wire at the center to form a V (in any direction) reduces the

broadside gain and increases the gain in the plane of the wire--or off the wire ends. For a given height above ground and with the wire ends downward, a certain angle will yield nearly equal beamwidths both broadside and end-wise. The ground constants and the height of the wire ends above ground form variables that alter the exact pattern shape. The modeled examples above average ground form a general solution for each of the 4 frequency ranges.

The inverted-V configuration also simplifies placing the antenna within the range of optimal NVIS performance. The effective height (Heff) of an inverted-V is as follows.

$$H_{eff} = 0.67 (H_{max} - H_{min}) + H_{min}$$

Hmax is the maximum height of the V and Hmin is the height of the wire ends above ground. Combining the required V angle and the low height of the wire ends above ground yields an effective height that falls within the range of effective NVIS heights (0.1 to 0.2 λ).

Table 5 shows the anticipated performance of the antennas over average ground. Values appear for F (the lowest frequency), 1.5 F, and 2 F. All antennas consist of AWG #12 wire in test models. However, the wire size makes little difference to antenna performance, allowing variation according to the needs developed from climate studies for any given installation location. Inter-spaced with the tabular reports are sample patterns for each version of the antenna (**Fig. 8** through **Fig. 11**) showing the broadside and wire-end patterns. (See **Appendix 1** for a comparison of inverted-V doublet performance with the performance of equivalent wide-band terminated folded dipoles.)

Table 5. Anticipated (Modeled) Performance of the Inverted-V NVIS Antennas

A. 1.875-3.75 MHz (See **Fig. 8**.)

Frequency MHz	Max. Gain dBi	Beamwidth Broadside degrees	Beamwidth End-wise degrees
1.875	3.27	100	98
2.8125	4.17	107	95
3.75	4.26	113	82

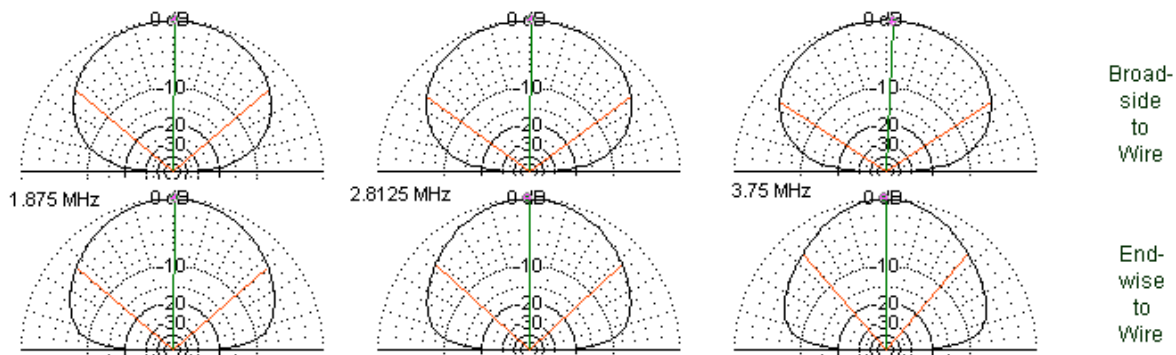

Inverted-V in Wide-Band NVIS Service: 1.875 - 3.75 MHz

Fig. 8

B. 3.75 - 7.5 MHz (See Fig. 9.)

Frequency MHz	Max. Gain dBi	Beamwidth Broadside degrees	Beamwidth End-wise degrees
3.75	2.67	104	99
5.625	3.48	113	99
7.5	3.38	119	91

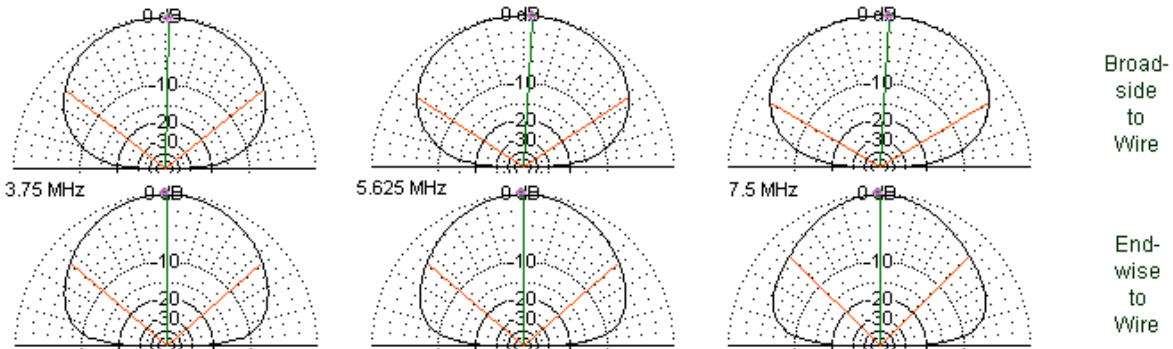

Inverted-V in Wide-Band NVIS Service: 3.75 - 7.5 MHz

Fig. 9

C. 7.5 - 15 MHz (See Fig. 10.)

Frequency MHz	Max. Gain dBi	Beamwidth Broadside degrees	Beamwidth End-wise degrees
7.5	1.93	106	97
11.25	3.09	105	97
15.0	3.09	120	95

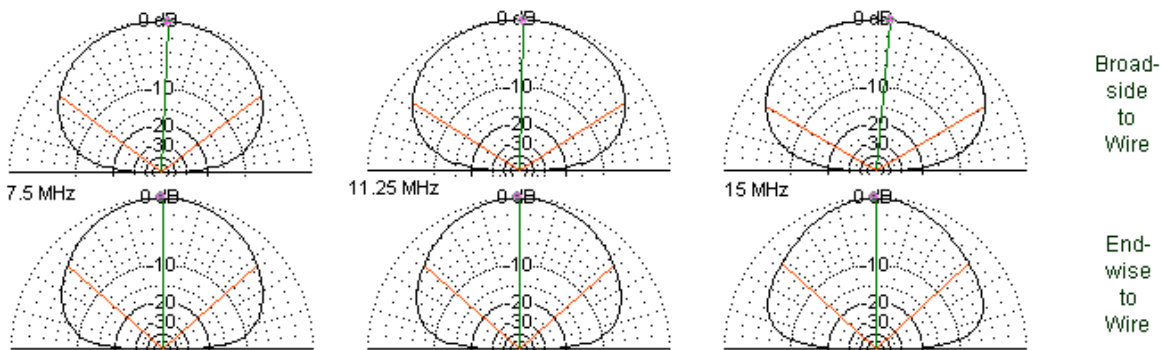

Inverted-V in Wide-Band NVIS Service: 7.5 - 15 MHz

Fig. 10

D. 15 - 30 MHz (See Fig. 11.)

Frequency MHz	Max. Gain dBi	Beamwidth Broadside degrees	Beamwidth End-wise degrees
15.0	1.88	108	93
22.5	3.18	116	94
30.0	3.25	122	89

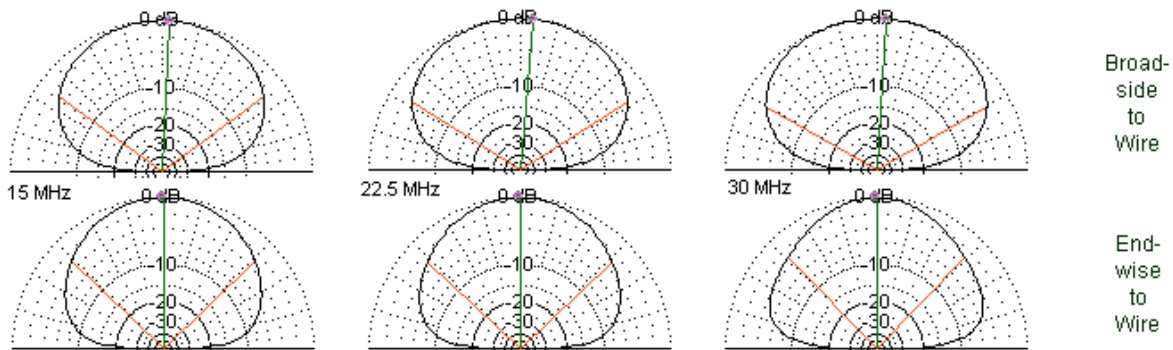

Inverted-V in Wide-Band NVIS Service: 15 - 30 MHz

Fig. 11

The tabular data illustrates the changing effects of the ground with the operating frequency. The set of inverted-V antennas at the sizes, angles, and heights above ground come as close as possible to providing ideal NVIS patterns. Increasing the frequency generally lowers the maximum gain available. Indeed, the maximum gain is less than we might achieve with a narrow-band dipole or loop at optimum NVIS height above ground. However, the goal of this design exercise is to produce nearly ideal patterns with reasonably consistent gain over each individual antenna range and over the entire set of antennas. The maximum gain change from 1.875 MHz to 30 MHz is under 2.5 dB. See **Appendix 2** for the performance of the doublets over more extreme ground conditions, both better and worse than average.)

3. *Feeding and Matching the Antennas:* The feedpoint impedance exhibited by each antenna varies greatly across the range of operating frequencies. For minimal loss, each antenna should use a length of parallel transmission line from the wire feedpoint to a matching system near the base of the antenna's central support. For illustrative purposes, I have modeled the range B (3.75-7.0-MHz) inverted-V with a 45' length of 450-Ω line with a velocity factor of 1.0. **Fig. 12** shows the resistive and reactive components of the impedance at the end of the line. These values will also approximate those shown by comparable installations for the other 3 antennas. Precise values will vary with ground conditions and normal installation variations.

Note that for much of the operating range, the resistive component of the new feedpoint impedance is quite low--close to about 50 Ω. For this portion of the range, the chief requirement of any matching system is the ability to compensate for the reactance. However, at the lower end of the operating range, the resistive and reactive components of the new feedpoint impedance are quite high.

The values of the impedance components depend upon the use of proper techniques of parallel transmission-line installation. If the center support is conductive, the line must be well spaced

from the support to prevent interaction that may unbalance the line or effect coupling to the support. Even non-conductive supports can benefit from careful line installation.

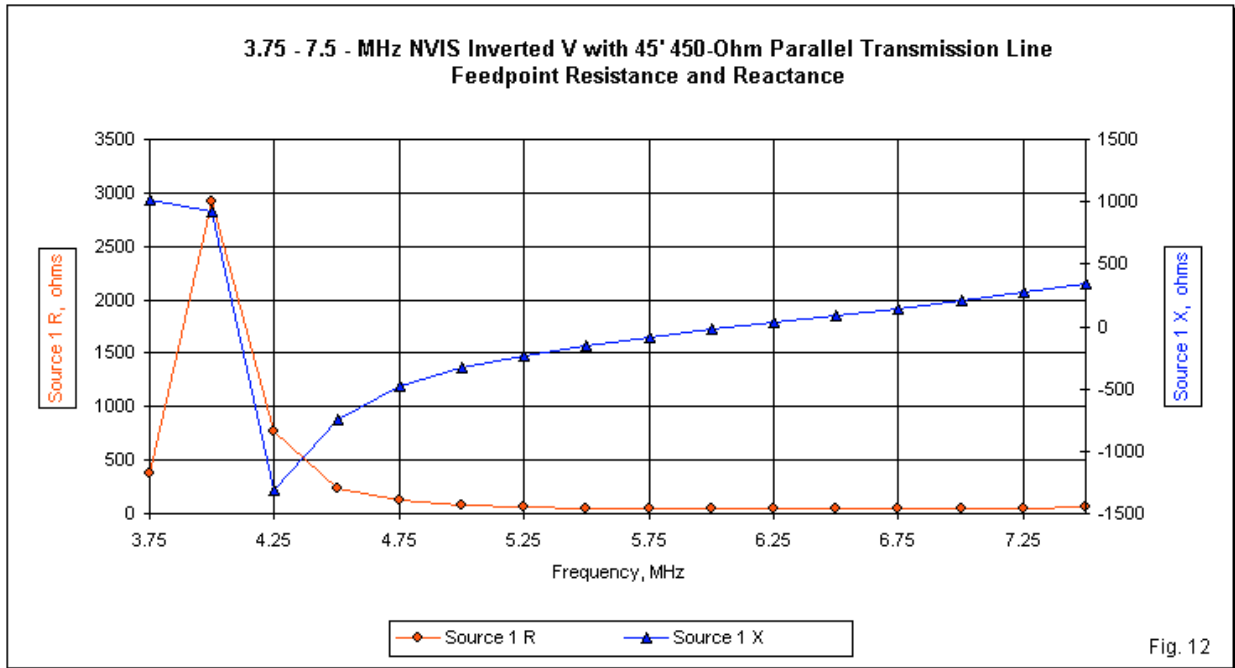
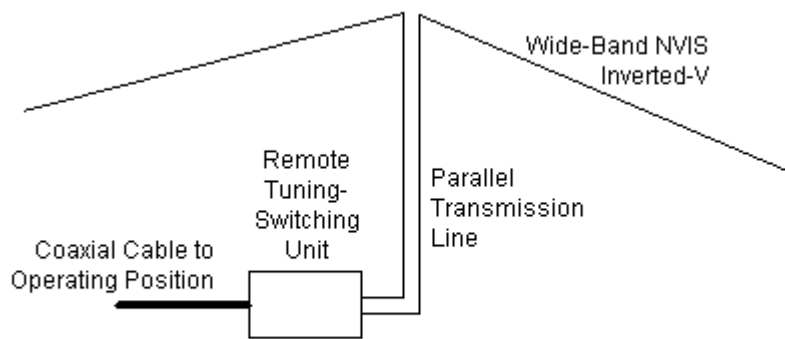

Fig. 12

Each of the 4 antennas should have a matching network box at its base, as suggested by the sketch in **Fig. 13**. Note that the box is labeled as not just a container for matching, but as well for switching. (It is possible to run parallel lines from each antenna to units encased within the operations building or vehicle. However, parallel transmission line tends to be less robust than coaxial cable. Hence, base-mounted units for each antenna with well-sheathed transmission and control cables are specified in these notes.)



General Outline: Antenna-Matching System

Fig. 13

The techniques required for effective use of the 4-antenna NVIS system involves many of the same software-control systems used for frequency agility along with comparable techniques for remote antenna tuning. The effectiveness of the system requires two new elements: multiple network matching systems in each box and rapid switching between networks.

Consider **Fig. 14**, a very generalized outline of a switching and matching box associated with any one of the 4 antennas.

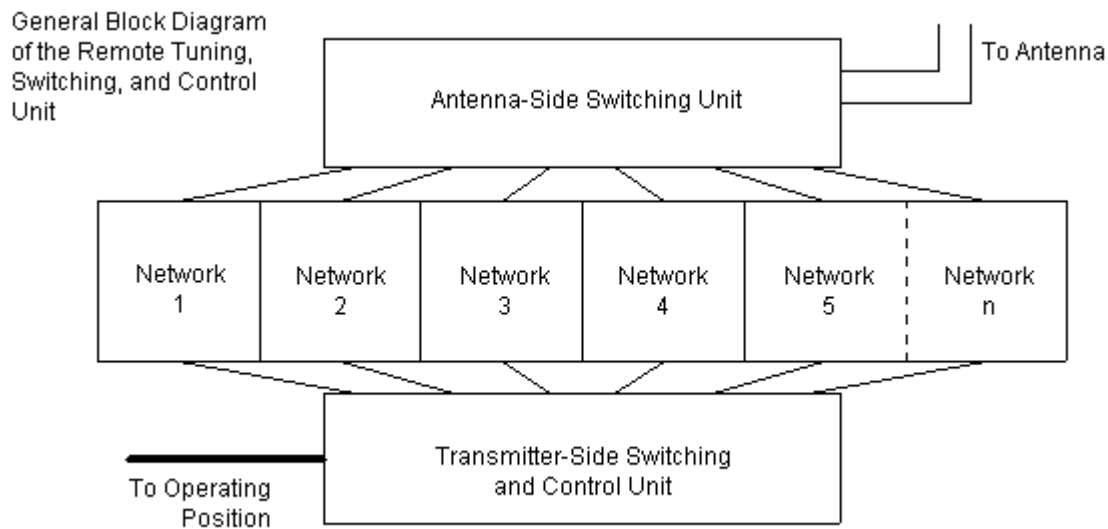

Fig. 14

- a. The box contains as many variable or switched network matching systems as the antenna range has frequencies of potential use (or reasonably narrow frequency bands of potential use).
- b. Controlling software has at least 2 modes: tune and switch. The "tune" mode is applied daily or whenever there is a significant shift in weather or other conditions that might affect the impedance of the antenna at the terminals to the matching networks. In this mode, on each frequency, the unit automatically finds the matching conditions for a given network and its assigned frequency (or frequency band). Once found, the components in that network are locked until the unit re-enters the tune mode and selects that network and its operating frequency. When locked, the unit is in the "switch" mode.
- c. Under normal operation for communications, as the operating station scans frequencies for the best one to use, it also switches the operative antenna and/or matching network. Hence, the only delay in operation is the switching time, which can be as low as a few milliseconds. With proper switching transient protection and suppression, an operator need not be aware of either a change in network or a total change of antenna and network.

By moving the matching to a set of matching networks, the complex portion of the system is transferred to a fully enclosed and weatherproof container that requires no field maintenance. Field replacement of the unit brings a given antenna back into operation in the event of a switching or matching malfunction. I do not underestimate the design considerations involved in developing the matching units, but the component numbers and sizes for each unit are reduced by the 2:1 frequency range of each antenna in the set.

Conclusion

The notes in this exercise provide the basis for an alternative approach to developing a true NVIS antenna system for 1.875 through 30 MHz. The goal of obtaining satisfactory NVIS far-field patterns is satisfied by the use of 4 inverted-V antennas close to ground and angled to

provide nearly equal broadside and wire-end elevation patterns, all having a 90° beamwidth. In addition, the system is relatively compact, with only simple structures exposed to weather degradation. Hence, the system is also relatively easy to maintain.

Note: The NVIS system is not designed to replace other HF antennas with low elevation angles used for long range skip communications. Nor is it designed to replace VHF and UHF communications antennas. However, some of the other antennas may be mounted on the center support structures used for at least the 2 lower-frequency antennas in the group. **Fig. 15** shows one of many potential layouts for the antenna system.

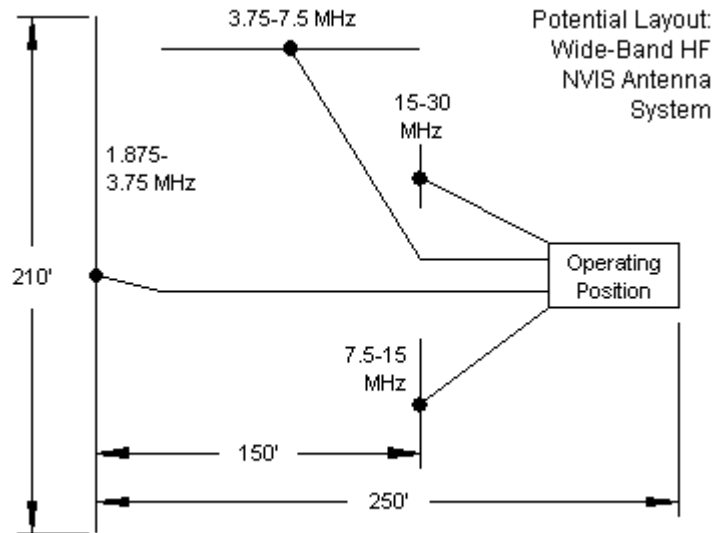

Fig. 15

The resulting NVIS system has relatively uniform--if modest--maximum gain across its range of use. Combined with uniform patterns and efficient transmitting and receiving equipment, the total system should effect considerable improvement of NVIS communications.

The matching and switching functions required by the 2:1 frequency range of each antenna call for a second alteration of thinking about NVIS antennas for wide-band use. Each antenna has a unit consisting of as many matching networks as there are operating frequencies (or narrow frequency bands). In normal operation, each frequency is pre-tuned for an acceptable match at the transmitting and receiving equipment. Software controlled switching linked to the frequency switching of the equipment effect very fast changes to optimize the selected antenna and network in real operating time. By consolidating the matching and switching functions for each antenna within a single weatherproof unit, the system enhances field maintenance requirements.

03-01-2006

Appendix 1. A Comparison of Standard Inverted-V Doublets and Wide-Band Terminated Folded Dipoles for NVIS Service

The wide-band terminated folded dipole (WBTFD) is a popular antenna for NVIS service. To obtain nearly circular azimuth patterns, one may use it in an inverted-V configuration. As well, the WBTFD holds the potential for presenting a 50- Ω feedpoint impedance by placing an appropriate balun between the wire feedpoints and the coaxial cable. The SWR swings normally do not exceed 2.5:1 at the balun terminals and may be less if we account for both balun and cable losses.

To overcome the problem of pattern shape, some experts recommend the use of a multiple antenna system, similar to the 4-doublet system explored in the main body of notes. To test the performance of such a system, I created WBTFD versions of the 4 antennas explored. **Fig. 16** shows the general outline, with the inverted-V doublet for comparison.

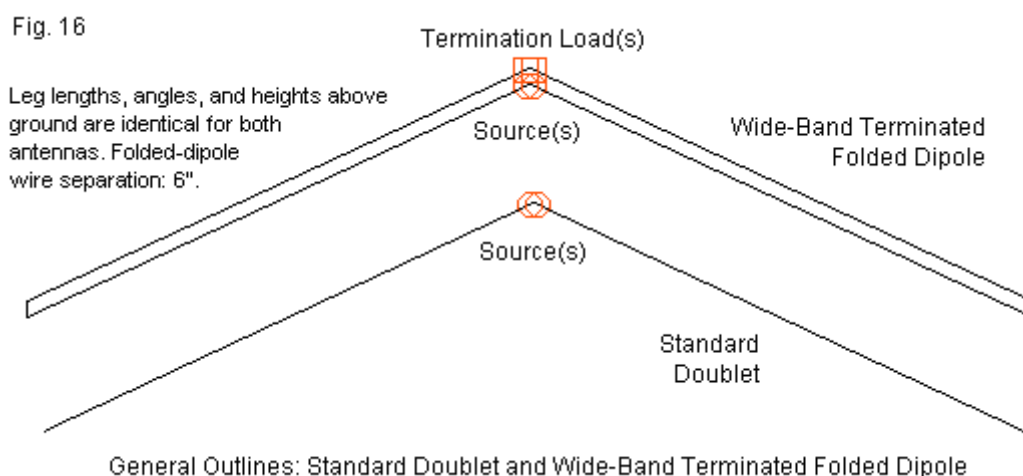

Each WBTFD uses the same overall leg length, wire angle, total span, and heights above ground as the corresponding doublet. For all antennas, the WBTFD wire separation is 6". The wire size remains AWG #12 (0.0808" diameter). Because a folded dipole or any parallel wire configuration acts similarly to a fat single wire, the electrical length of the WBTFDs is slightly longer than the length of the doublets. However, length changes of up to 0.1 to 0.2 λ do not materially affect performance. Such changes only create minor changes in the precise beamwidth values.

For a comparison between the performance of the WBTFDs and the inverted-V doublets, I set the new antennas over average ground. Therefore, the performance values shown in **Table 6** correspond directly to those shown in **Table 5** in the main body of notes. Because the pattern shapes are identical for both sets of antenna, I have not repeated the elevation patterns shown in **Fig. 8** through **Fig. 11**. A comparison of the beamwidth data in the 2 relevant tables will quickly confirm the identity of pattern shapes.

Table 6. Anticipated (Modeled) Performance of the Inverted-V WBTFD NVIS Antennas

A. 1.875-3.75 MHz (See **Fig. 8.**)

Frequency MHz	Max. Gain dBi	Beamwidth Broadside degrees	Beamwidth End-wise degrees	Feedpoint Impedance R +/- jX Ω	800- Ω SWR
1.875	-3.38	100	99	920 + j410	1.63
2.8125	-2.46	107	96	1150 - j740	2.29
3.75	-3.47	112	83	630 - 210	1.46

B. 3.75 - 7.5 MHz (See **Fig. 9.**)

Frequency MHz	Max. Gain dBi	Beamwidth Broadside degrees	Beamwidth End-wise degrees	Feedpoint Impedance R +/- jX Ω	800- Ω SWR
3.75	-3.61	104	100	990 + j420	1.67
5.625	-2.53	113	101	1030 - j690	2.19
7.5	-3.60	118	96	590 - j200	1.53

C. 7.5 - 15 MHz (See **Fig. 10.**)

Frequency MHz	Max. Gain dBi	Beamwidth Broadside degrees	Beamwidth End-wise degrees	Feedpoint Impedance R +/- jX Ω	800- Ω SWR
7.5	-4.05	106	99	1020 + j410	1.66
11.25	-2.41	114	101	970 - j670	2.15
15.0	-3.35	118	106	540 - j220	1.66

D. 15 - 30 MHz (See **Fig. 11.**)

Frequency MHz	Max. Gain dBi	Beamwidth Broadside degrees	Beamwidth End-wise degrees	Feedpoint Impedance R +/- jX Ω	800- Ω SWR
15.0	-4.14	107	95	1040 + j350	1.59
22.5	-1.82	116	98	900 - j630	2.09
30.0	-2.56	119	100	490 - j230	1.84

The impedance and SWR columns confirm the typical WBTFD patterns of variations as the antenna length effectively doubles between the lowest and highest frequencies for each version. See **Fig. 5** as a reference for the typical undulation pattern for SWR in a WBTFD. The SWR values, when translated via a balun or similar device to 50- Ω values are well within the limits usually specified for wide-band antenna systems.

The beamwidth columns establish that both the doublet and WBTFD versions of the NVIS inverted-V antennas share the same values within limits that are beyond measurement and that will vary more from one installation to another than they will in models.

The key difference in performance that favors the doublets--despite the more complex matching requirements--is gain. **Table 7** compares the gain values for the doublets and the WBTFDs at each tabulated frequency.

Table 7. Comparison of Maximum Gain Values of Inverted-V Doublets and WBTFDs in NVIS Service: gain values in dBi; difference and average values in dB.

Antenna & Difference	Frequency (MHz)	Average	Overall Average	
Version A	1.875	2.8125	3.75	
Doublet	3.27	4.17	4.26	
WBTFD	-3.58	-2.46	-3.47	
Difference	6.85	6.63	7.73	7.07 dB
Version B	3.75	5.625	7.5	
Doublet	2.67	3.48	3.38	
WBTFD	-3.61	-2.53	-3.60	
Difference	6.28	6.01	6.98	6.42 dB
Version C	7.5	11.25	15.0	
Doublet	1.93	3.09	3.09	
WBTFD	-4.05	-2.41	-3.35	
Difference	5.98	5.50	6.44	5.97 dB
Version D	15.0	22.5	30.0	
Doublet	1.88	3.18	3.25	
WBTFD	-4.14	-1.82	-2.56	
Difference	6.02	5.00	5.81	5.61 dB
				6.27 dB

The clear and consistent pattern is a loss of 6 dB or more in received and transmitted signal strength due to the power dissipated in the terminating resistor of the WBTFD version of the antenna. In the transmitting mode, one needs 4 times the power output to yield the same signal strength at a receiving site. In the receiving mode, the differential is well over 1 S-unit, which can make a very large difference in the readability of a signal that is near the receiving threshold level. WBTFD antennas are best suited to receiving applications in the presence of moderate to strong signals. However, they tend to show their limitations when working with threshold-level signals. The standard doublet provides a 6-dB gain advantage in both transmit and receive modes, and the requirement for complex matching and switching systems may be well worth the extra effort to develop such a system.

Appendix 2. A Comparison of Standard Inverted-V Doublets over Very Poor, Average, and Very Good Ground

Antenna gain and beamwidth tend to vary somewhat as we change the quality of the ground below. The effect grows stronger with antennas that approach the ground closely, as do the ends of the inverted-V doublets used in this design exercise. To sample the effects of ground quality on the performance of the inverted-V doublets in NVIS service, I ran all NEC-4 doublet models over 3 levels of ground quality:

Very Poor: conductivity 0.001 S/m, relative permittivity 5
 Average: conductivity 0.005 S/m, relative permittivity 13
 Very Good: conductivity 0.0303 S/m, relative permittivity 20

The results for each version of the antenna appear in **Table 8**.

Table 8. Performance of the NVIS Inverted-V Doublets over Various Grounds

A. 1.875 - 3.75 MHz

Very Poor Ground		Beamwidth	Beamwidth
Frequency	Max. Gain	Broadside	End-wise
MHz	dBi	degrees	degrees
1.875	1.44	107	95
2.8125	2.88	117	87
3.75	3.26	123	74
Average Ground		Beamwidth	Beamwidth
Frequency	Max. Gain	Broadside	End-wise
MHz	dBi	degrees	degrees
1.875	3.27	100	98
2.8125	4.17	107	95
3.75	4.26	113	82
Very Good Ground		Beamwidth	Beamwidth
Frequency	Max. Gain	Broadside	End-wise
MHz	dBi	degrees	degrees
1.875	4.95	97	100
2.8125	5.27	103	102
3.75	5.04	107	91

B. 3.75 - 7.5 MHz

Very Poor Ground		Beamwidth	Beamwidth
Frequency	Max. Gain	Broadside	End-wise
MHz	dBi	degrees	degrees
3.75	1.04	113	94
5.625	2.30	123	91
7.5	2.41	128	84
Average Ground		Beamwidth	Beamwidth
Frequency	Max. Gain	Broadside	End-wise
MHz	dBi	degrees	degrees
3.75	2.67	104	99
5.625	3.48	113	99
7.5	3.38	119	91

Very Good Ground		Beamwidth	Beamwidth
Frequency	Max. Gain	Broadside	End-wise
MHz	dBi	degrees	degrees
3.75	4.48	99	103
5.625	4.67	107	110
7.5	4.27	113	107

C. 7.5 - 15 MHz

Very Poor Ground		Beamwidth	Beamwidth
Frequency	Max. Gain	Broadside	End-wise
MHz	dBi	degrees	degrees
7.5	0.69	115	94
11.25	2.03	123	92
15.0	2.18	128	89

Average Ground		Beamwidth	Beamwidth
Frequency	Max. Gain	Broadside	End-wise
MHz	dBi	degrees	degrees
7.5	1.93	106	97
11.25	3.09	105	97
15.0	3.09	120	95

Very Good Ground		Beamwidth	Beamwidth
Frequency	Max. Gain	Broadside	End-wise
MHz	dBi	degrees	degrees
7.5	3.85	100	102
11.25	4.22	109	106
15.0	3.91	115	100

D 15 - 30 MHz

Very Poor Ground		Beamwidth	Beamwidth
Frequency	Max. Gain	Broadside	End-wise
MHz	dBi	degrees	degrees
15.0	0.85	116	92
22.5	2.18	124	90
30.0	2.34	129	85

Average Ground		Beamwidth	Beamwidth
Frequency	Max. Gain	Broadside	End-wise
MHz	dBi	degrees	degrees
15.0	1.88	108	93
22.5	3.18	116	94
30.0	3.25	122	89

Very Good Ground		Beamwidth	Beamwidth
Frequency	Max. Gain	Broadside	End-wise
MHz	dBi	degrees	degrees
15.0	3.43	103	97
22.5	4.01	112	98
30.0	3.84	119	88

Of the 72 beamwidth values listed, only 8 fall below 90° and only 1 below 80°. Most of the variations occur over very poor soil, but only one of the variations is sufficiently large enough to create a pattern more oval than circular. The inverted-V doublets as shown in the dimension charts thus satisfy the needs of omni-directional very high angle patterns.

Appendix 3. A Comparison of Standard Inverted-V Doublets over Very Poor, Average, and Very Good Ground with and without a Ground Screen

To evaluate the probable effects of covering the ground with a screen, I modeled the low-frequency version of the inverted-L doublet (1.875 - 3.75 MHz) both with and without a screen. So as not to unduly enhance the effects of the screen, I converted the theoretical models that used lossless wire to copper wire with its finite conductivity. Hence, the gain values for the non-screen version of the array will be slightly lower than previously reported in the main body of these notes.

The likely effect of a ground screen--if sufficiently large--with respect to an array with primarily upward radiation is to reduce, but not eliminate, the effects of ground quality upon antenna performance. The subject antenna covers a ground length of 210' with negligible width. A ground screen must be at least $\frac{1}{2}\lambda$ longer in each dimension to be fully effective as a planar reflector. The screen modeled was 524' wide (broadside to the wire) and 734' long (length-wise to the wire). The screen was 0.1' above ground to prevent the wires from intersecting with $Z=0$ within NEC-4. Each square in the wire-grid simulation was 0.05λ per side, with 1" diameter wire. This structure falls short of NEC recommendations for a wire diameter that is the side length of a cell divided by π . However, the model used 1270 segments and provides a reasonably good approximation of a true screen. **Fig. 17** shows the outline of the subject antenna and its wire-grid screen.

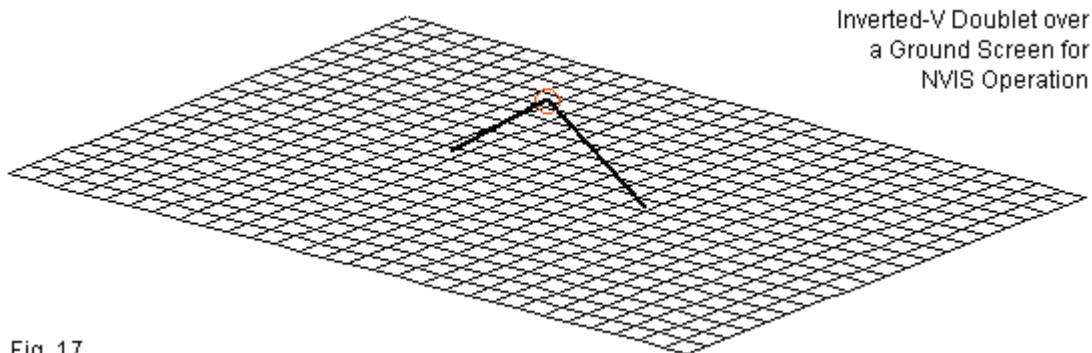

Fig. 17

The inverted-L for the low band is 5' above ground and hence 4.9' above the screen. The peak height of the antenna remains at 75' above ground.

Table 9 presents the data for the copper antenna without a ground screen for very poor, average, and good soils as defined elsewhere in this report.

Table 9. Performance of the 1.875 - 3.75-MHz Copper NVIS Inverted-V Doublets over Various Grounds Using No Ground Screen

Very Poor Ground		Beamwidth	Beamwidth
Frequency	Max. Gain	Broadside	End-wise
MHz	dBi	degrees	degrees
1.875	1.31	107	95
2.8125	2.80	116	87
3.75	3.19	123	74

Average Ground		Beamwidth	Beamwidth
Frequency	Max. Gain	Broadside	End-wise
MHz	dBi	degrees	degrees
1.875	3.06	100	98
2.8125	4.08	108	95
3.75	4.19	113	81
Very Good Ground		Beamwidth	Beamwidth
Frequency	Max. Gain	Broadside	End-wise
MHz	dBi	degrees	degrees
1.875	4.64	97	100
2.8125	5.16	103	102
3.75	4.99	107	91

Although the gain decreases by a little over a quarter of a dB when we shift to copper wire from lossless wire, the beamwidth values are virtually identical to the earlier ones for all types of soil.

When we add a low screen of the prescribed dimensions, we obtain the results in **Table 10**. The screen and the antenna wires are all copper.

Table 10. Performance of the 1.875 - 3.75-MHz Copper NVIS Inverted-V Doublets over Various Grounds Using a Ground Screen 0.1' above Ground

Very Poor Ground		Beamwidth	Beamwidth
Frequency	Max. Gain	Broadside	End-wise
MHz	dBi	degrees	degrees
1.875	4.37	98	104
2.8125	4.59	103	106
3.75	4.69	111	71
Average Ground		Beamwidth	Beamwidth
Frequency	Max. Gain	Broadside	End-wise
MHz	dBi	degrees	degrees
1.875	4.56	97	101
2.8125	4.82	104	104
3.75	4.77	109	84
Very Good Ground		Beamwidth	Beamwidth
Frequency	Max. Gain	Broadside	End-wise
MHz	dBi	degrees	degrees
1.875	5.11	96	100
2.8125	5.35	102	105
3.75	5.16	106	94

The presence of a satisfactorily large ground screen has two significant effects. Foremost is the fact that it levels the maximum gain among the various soil qualities. The maximum gain spread for all frequencies in the operating range of the subject antenna with no ground screen was 3.85 dB. With the screen in place, the spread drops to 0.98 dB, nearly a 3-dB improvement. The screen's improvement is most dramatic over very poor soil and least so over very good soil. The screen is therefore recommended for all soils ranging from average to very poor.

The second effect is minor but noticeable in models. The end-wise beamwidth narrows at 2 F (3.75 MHz in this case), which is below the desired 90° level. Over very poor soil, the narrowing

increases slightly. We shall see further evidence of this phenomenon in the final experiment in this series.

To test the effects of an elevated screen and antenna, I raised the entire structure 5' further above ground. The screen is now at 5.1' above ground, with the top of the antenna 80' above ground. Under these test conditions, we obtain the results in **Table 11**.

Table 11. Performance of the 1.875 - 3.75-MHz Copper NVIS Inverted-V Doublets over Various Grounds Using a Ground Screen 5.1' above Ground

Very Poor Ground		Beamwidth	Beamwidth
Frequency	Max. Gain	Broadside	End-wise
MHz	dBi	degrees	degrees
1.875	5.09	101	102
2.8125	4.96	102	105
3.75	5.49	105	58 *
Average Ground		Beamwidth	Beamwidth
Frequency	Max. Gain	Broadside	End-wise
MHz	dBi	degrees	degrees
1.875	5.20	101	101
2.8125	5.31	102	101
3.75	5.54	105	78
Very Good Ground		Beamwidth	Beamwidth
Frequency	Max. Gain	Broadside	End-wise
MHz	dBi	degrees	degrees
1.875	5.60	100	101
2.8125	5.77	101	98
3.75	5.70	106	83

With the elevated screen, we discover the beginnings of serious pattern distortion with respect to the ideal conditions specified at the beginning of this report: a circular azimuth pattern with a beamwidth of 90°. **Fig. 18** shows how the tabular numbers for 3.75 MHz over very poor soil resolve into elevation patterns.

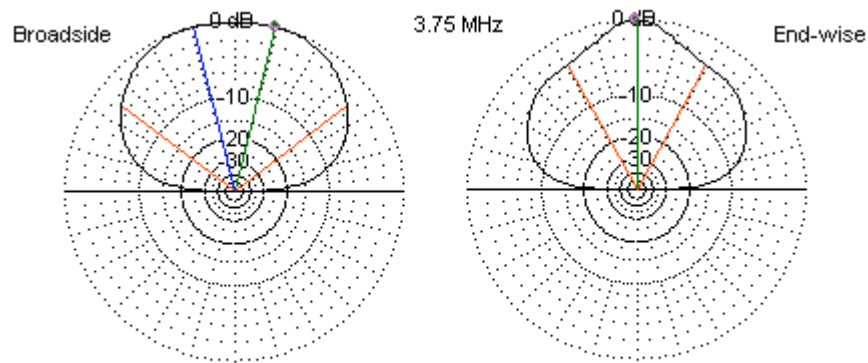

Elevation Patterns of the Low-Band Inverted-V NVIS Antenna at 3.75 MHz with the Ground Screen Elevated 5'

Fig. 18

The broadside pattern begins to show a double peak, although the zenith value is only slightly below the peak value. More serious is the decay of the end-wire patterns as it develops a

vertical peak and more rapid sloping of the sides. The result is a minaret (or candy kiss) shape with a narrow beamwidth. Over better soils, the effect is less pronounced, but still present.

A ground screen is a desirable addition to the inverted-V doublet system of NVIS antennas, especially for soil qualities that are average or worse. The screen--if sufficiently large--improves gain slightly, but more importantly levels the gain and beamwidth performance as the system moves from one ground quality to another.

Elevating the screen and the antenna is not likely to achieve any significant positive results. Moreover, it may degrade performance over a portion of the operating spectrum of each antenna. As well, an elevated screen would likely be impossible to maintain in any but the most benign weather conditions.

To elevate the antennas alone presents some difficulties with respect to performance. To obtain a nearly circular pattern with the ends and top raised requires a more radial angle of down-slope for each leg of the V. As the downward angle increases, the gain at the zenith angle decreases. At some point in the progression, the antenna takes on the pattern of a vertical antenna with a null in the zenith direction. In contrast, flattening the Vee by raising the ends increases zenith gain. However, it also creates an oval pattern with considerably less beamwidth end-wise than broadside to the wire. At a certain point in the progression, the antenna becomes a linear doublet with maximum gain broadside to the antenna and nulls off the wire ends. How far one should carry either process requires technical specifications that include consideration of physical and climatic conditions as well as the electrical performance of the antenna. Electrically, the key question will become how much pattern distortion from a circle is acceptable for reasonable NVIS operations.

At the present stage of concept development, those specifications are not present. Once devised, such specifications will guide any further antenna design work.

Appendix 4. A Possible Alternative Inverted-V Wide-Band NVIS Antenna Set with New Dimensions

For situations calling for a minimum safe height of inverted-V wires above ground (to avoid encapsulation by snow, rising water, etc.), I redeveloped the antenna set. The new set of 4 antennas uses a minimum height of 5' above ground level. To effect patterns as close to the ideal as feasible, the legs of each antenna slope downward 45° relative to horizontal. In addition, the length of the antennas has been shortened so that at each low-frequency point, they are about $\frac{3}{8} \lambda$ and at the high-frequency point, they are $\frac{3}{4} \lambda$.

The revision avoids one problem--snow coverage--but presents a new challenge to matching. We shall address this challenge before closing this note. In general, the system potentially performs about as well as the original, although there is an interesting pattern phenomenon in the highest band due to the elevated minimum height above ground.

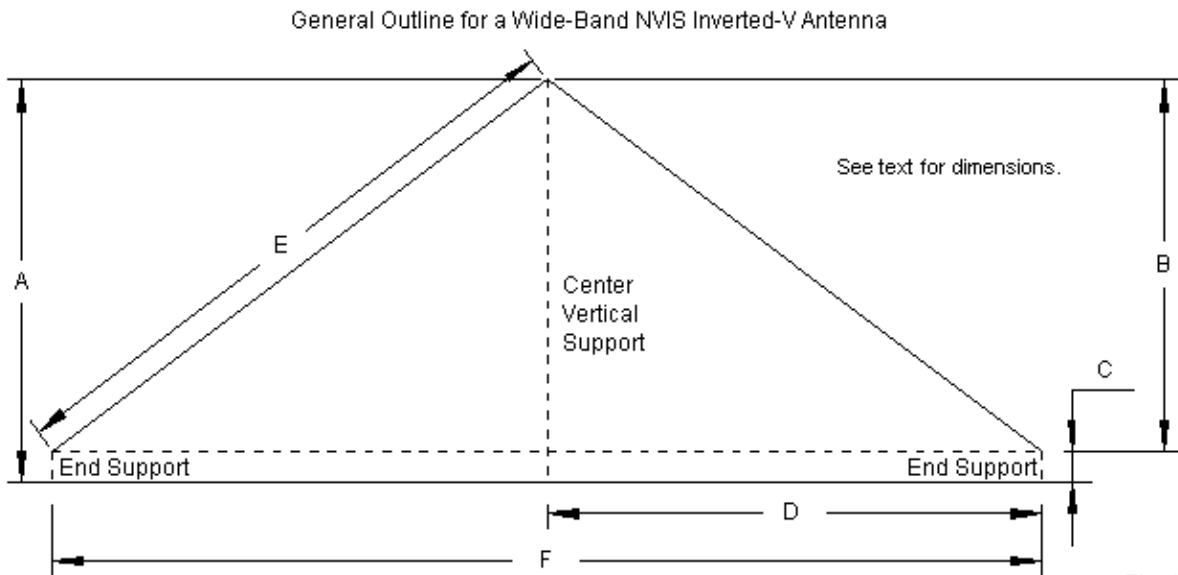

Fig. 19 repeats **Fig 7** from the main body of notes as a guide to **Table 12**, the dimensions for the revised set of inverted-V antennas.

Table 12. Revised Dimensions of Inverted-V Antennas in NVIS Service: All dimensions in feet

Frequency Range MHz	A Total height above ground	B Antenna height	C Wire end height	D Leg length horizontally	E Leg length diagonally	F Total horizontal span
1.875 - 3.75	75	65	10	65	92	130
3.75 - 7.5	37.5	32.5	5	32.5	46	65
7.5 - 15	21.25	16.25	5	16.25	23	32.5
15 - 30	13.125	8.125	5	8.125	11.5	16.25

Table 13 provides the performance values for the revised antennas. Compare the values to those in **Table 5** to see the similarities and differences. Over average ground, the beamwidth (end-wire to the wire) falls more than 5° below the idealized 90° value in only 2 instances, all on

the highest band (15-30 MHz). Some maximum gain entries show two values, a situation that will be fully described following the tabulated values.

Table 13. Anticipated (Modeled) Performance of the Revised Inverted-V NVIS Antennas

A. 1.875-3.75 MHz

Frequency MHz	Max. Gain dBi	Beamwidth Broadside degrees	Beamwidth End-wise degrees
1.875	3.12	100	95
2.8125	4.10	109	97
3.75	4.03	119	100

B. 3.75 - 7.5 MHz

Frequency MHz	Max. Gain dBi	Beamwidth Broadside degrees	Beamwidth End-wise degrees
3.75	2.15	103	94
5.625	3.48	112	94
7.5	3.62	121	88

C. 7.5 - 15 MHz

Frequency MHz	Max. Gain dBi	Beamwidth Broadside degrees	Beamwidth End-wise degrees
7.5	2.74	107	87
11.25	3.90	118	88
15.0	3.85/3.92	129	91

D. 15 - 30 MHz

Frequency MHz	Max. Gain dBi	Beamwidth Broadside degrees	Beamwidth End-wise degrees
15.0	3.97	113	81
22.5	4.35/4.41	129	84
30.0	3.39/4.52	140	93

Increased elevation of the high-band inverted-Vs tends to increase gain at the low end of each range. Otherwise, gain values are very comparable to those for the original set of antennas. However, the requirement for added minimum wire height beyond the level that is proportional to the lower-range antennas creates the beginning of a split lobe. The 15-30-MHz range broadside and end-wise elevation patterns--shown in **Fig. 20**--illustrate the phenomenon. The patterns for 15 MHz are typical of all other patterns for table entries that show only a single gain value. The patterns are well behaved. In fact, if you compare **Fig. 19** with **Fig. 11**, you will see that the revised antennas avoid the "cone" shaped pattern at the high end of each band.

However, because the high-band antennas are elevated above their optimal electrical height to achieve a certain physical goal, the pattern begins to develop a double peak. The pattern for 22.5 MHz is also a clone for the pattern at 15 MHz with the 7.5-15-MHz antenna. The gain differential between the zenith value and the peak value is well below 0.1 dB. At the top end of the range--30 MHz--the double peak is more distinct, with a gain differential of about 1.1 dB.

The double-peak phenomenon is not strong enough to seriously affect antenna operation in the NVIS mode, although the azimuth pattern at an elevation angle of 45° would describe an oval rather than a near circle. Nonetheless, the end-wise beamwidth remains close to or in excess of the desired 90° value.

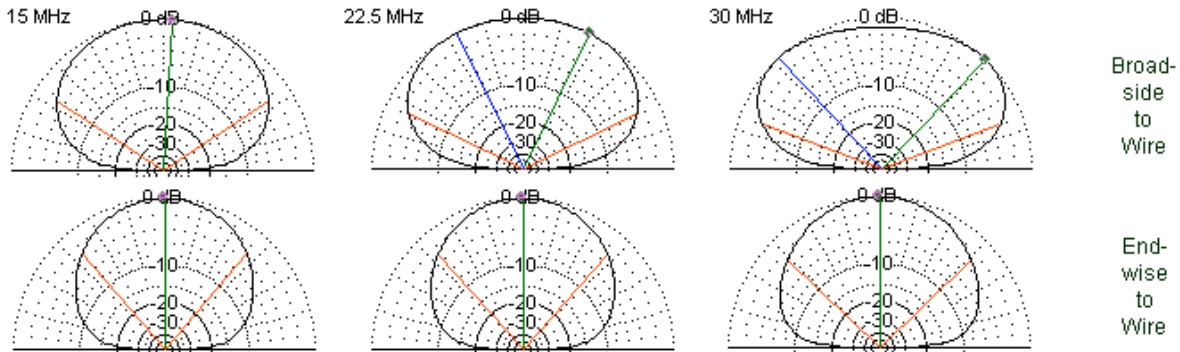

Compare Fig. 11

Revised Inverted-V Wide-Band NVIS Service: 15 - 30 MHz

Fig. 20

The revised inverted-V system presents an added challenge to the admittedly difficult matching and switching system proposed in the main body of notes. For all antennas, the impedances range from about $20 - j500 \Omega$ at the lowest used frequency to about $270 + j850 \Omega$ at the highest used frequency. The low end of each band presents a challenge insofar as a high ratio of reactance to a low resistance normally incurs high losses, even with open wire transmission lines. Therefore, I suggest the 2-stage system shown on block form in **Fig. 21**.

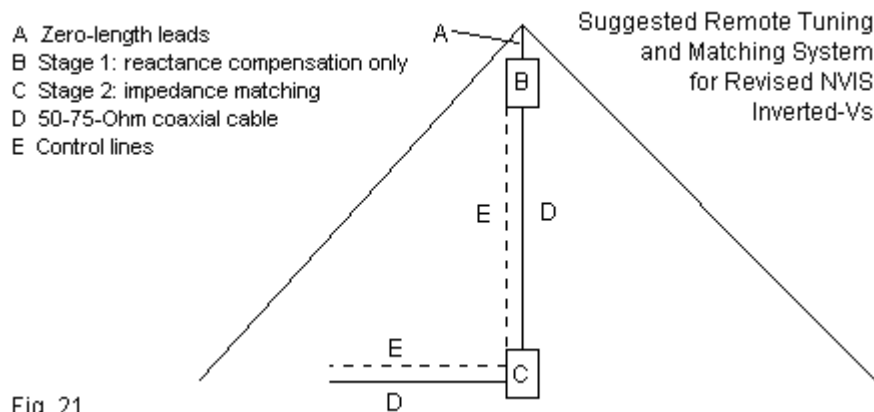

Fig. 21

Using near-zero-length leads (A) from the feedpoint to stage 1 (B), the first matching would only compensate for the reactance, leaving the resistive component alone for further transmission. A standard SWR detector would work satisfactorily, since it would show minimum SWR at the near-zero reactance level. The remaining resistive or near resistive impedance values would show a value of nearly 1:1 at mid-band to about 5.5:1 at the upper band limit. For a coaxial cable (D), the length of the center support, such values would not show significant loss at the terminals of stage 2 (C). However, the actual impedances would be complex due to the impedance transformation along the vertical cable. Stage 2 would effect final impedance transformation to the desired level (50-75 Ω resistive) for a matching the operating equipment.

One advantage of a 2-stage system is that stage 2 (the full impedance transformation network) would need only a limited range of components to effect a satisfactory match. The input impedances would have a restricted range of values compared to transforming values directly at the feedpoint terminals or with a single transmission line as suggested in the main body of notes. It is anticipated that the 2-stage system, even if time-stepped with feedback signals, would likely save time during the pre-tuning phase. As well, it is likely to save some switching devices used to select either the correct network or the correct components. The original system used antenna lengths that showed very rapid changes in both resistance and reactance as the impedance approached its peak values. However, the revised system has a broader impedance bandwidth with slow changes in impedance and lower extremes of reactance.

If the matching and switching challenges can be met, I would recommend this system over the original. It shares the same basic NVIS radiation patterns and achieves the same simplicity of weather-exposed components as the initial system, and it adds some advantages in terms of avoiding physical ground clutter.

Note: the effectiveness of a NVIS system depends upon true skywave reflection/reflection and the resulting skewed polarization. Such systems should not be confused with those designed for direct near-overhead communications with aircraft, wherein polarization of a signal. For such systems, one may use crossed inverted-V antennas. However, each antenna in a pair must be independently fed, with quadrature between established at the transmitter. Maintaining quadrature requires virtually exact duplication of matching systems and feedlines.

Appendix 5. A Possible Matching Scheme for the Alternative Inverted-V Wide-Band NVIS Antenna Set

The alternative wide-band NVIS antenna set of 4 inverted-Vs, described in **Appendix 4**, makes use of 2:1 frequency-range antennas scaled to cover the entire HF range from 1.875 to 30 MHz. Each antenna is approximately $3/8\lambda$ long at the low end of its range and about $3/4\lambda$ long at the high end. Near the geometric mean frequency within the range, the impedance is close to 50 Ω resistive. **Fig. 22** tracks the resistance and reactance at the antenna feedpoint for the version that covers 1.875 to 3.75 MHz.

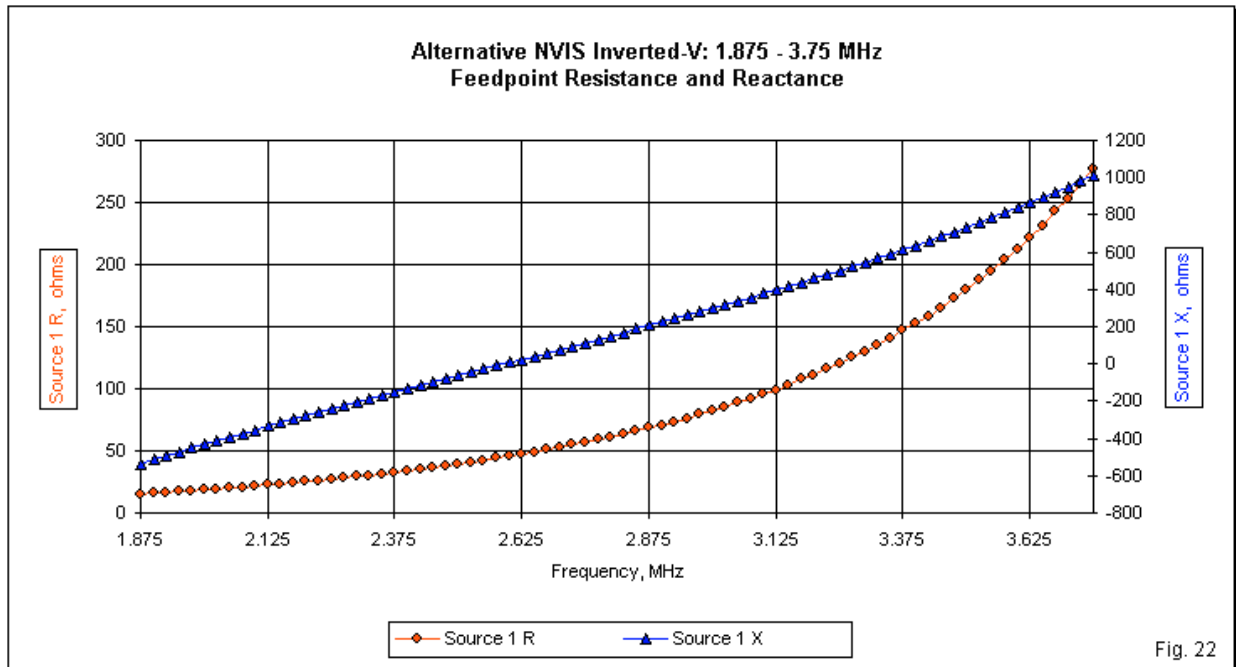

The rise in reactance across the passband is nearly linear, while the rise in resistance describes part of a more parabolic curve. The curves for all 4 antenna ranges are very similar and for practical design purposes may be considered identical. **Table 14** provides some outline data on the limits of each resistance and reactance range, along with the limits of the region in which the 50- Ω SWR is 2:1 or less without any matching network.

Table 14. Impedance Characteristics of the Alternative Wide-Band NVIS Inverted-V Antennas

Antenna	Low Frequency MHz	Impedance R +/- jX Ω	High Frequency MHz	Impedance R +/- jX Ω	2:1 50- Ω SWR Range MHz
A	1.875	16 - j534	3.75	277 + j1013	2.55 - 2.65
B	3.75	19 - j493	7.5	278 + j940	5.1 - 5.3
C	7.5	18 - j465	15	269 + j840	10.2 - 10.7
D	15	17 - j432	30	263 + j738	20.4 - 21.6

The values are for antennas over average ground. Impedances will vary slightly with changes in ground constants as well as for variations in construction or installation, especially with respect to the height of the wire ends above ground. Indeed, in some regions, variations may occur due to the presence or absence of ground cover, such as grasses or snow. A ground screen for the antenna site will minimize these changes.

To match each antenna to a master 50-Ω coaxial cable feedline requires a flexible remotely tuned set of matching networks. The matching "box" for each antenna should consist of as many networks as there are operating frequencies within the range of that antenna. Each antenna would be pre-tuned to each operating frequency on a regular schedule so that use of the antenna involves only switching in the correct network. **Appendix 4** shows a 2-box system, but it is likely that a 1-box system can be used, with the box mounted at the antenna feedpoint terminals with near-zero-length leads. A 1-box system would require sturdy mast structures for the 2 upper-frequency antennas to support the weight. For the 2 lower frequency antennas, a 3-legged tower is presumed and box support is not critical to tower selection.

More critical to the matching question is the speed of the "search and lock" phase of the pre-tuning regimen, since this operation should impose absolutely minimal downtime from normal operation. One way to achieve this goal is to reduce the number of variable or stepped components to an absolute minimum. To achieve this goal, we may set aside tuning the antenna for a perfect 1:1 50-Ω SWR and accept a wider limit for tuning. For this design exercise, I has arbitrarily set a 2:1 50-Ohm SWR limit, although some applications of NVIS technology use wider limits, such as 2.5:1 or 3:1. The absolute limit set is generally unimportant outside of establishing a software control value. The SWR curves are steep once past the 2:1 limit imposed on this design study.

The goal of the study was to determine if the matching network components can be reduced to a single variable or stepped component, with other network components being fixed. One way to achieve this goal is to use the 2 networks outlined in **Fig. 23**. The left-hand network is used for up-conversions from line to antenna, while the right-hand network is for down-conversion.

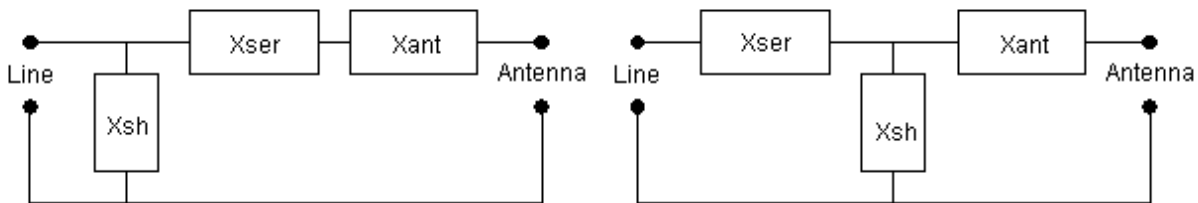

Forms of Possible Matching Networks Usable with the Alternative Wide-Band NVIS Antennas

Fig. 23

The network can be single-ended or use balanced series components (Xser and Xant). In either case, the transmission-line end of the network should employ a 1:1 ferrite-bead balun/choke of Maxwell design to attenuate common-mode currents on the coaxial cable braid.

We may reduce the variable or stepped component to just Xser or the serial reactance if we are willing to subdivide the operating range of each antenna into 5 sub-ranges for matching. On the premise that a 1-box remote matching box would use modular construction for easy replacement of the networks associated with each operating frequency, this provision would create no significant issues. One need only select the modules corresponding to the list of operating frequencies associated with the antenna at the time of installation. The modules can be changed either for maintenance or for a change in the operating frequency list using appropriate field maintenance procedures, followed by a pre-tuning of the replacement network.

To test the feasibility of the suggested system, I developed first-order network values for the 1.875-3.75-MHz antenna. Similar scaled networks would be needed for the other 3 antennas in the set. For the lowest frequency range, we may create 5 sub-bands for matching purposes. Each sub-band network will use fixed components for X_{ant} or the serial output reactance and for X_{sh} or the shunt or parallel reactance. Only X_{ser} will be variable or stepped. The general network element designation is expressed in terms of X or reactance, because 2 of the 3 components will shift from being capacitors to inductors, depending on the sub-band range. However, the variable component (X_{ser}) is always a capacitor for simplicity and compactness of construction.

Table 15 shows the values required for the first sub-band. Not all bands are of equal width. Test increments are 0.125 MHz or about 5% of the geometric mean frequency of the overall operating band. Fixed component values appear only for the first tabular entry. It uses the left-hand configuration of **Fig. 23**.

Table 15. Sub-Band 1 Components for Antenna A

Frequency MHz	X_{ant-L} μH	X_{sh-C} pF	X_{ser-C} pF	Approx. 50- Ω SWR
1.875	48	2000	5000	1.9
2.0			550	1.1
2.125			265	1.3
2.25			170	1.7

A 48- μH inductance essentially in series with the antenna element will reduce effective gain by about 0.5-dB for a coil Q of about 300. This reduction is small compared to the 6-dB gain reduction occasioned by the use of a terminated folded dipole inverted-V in the same location. Since capacitor Q values are normally much higher, their contributions to gain loss is largely negligible in this context. The required value of capacitance at 1.875 MHz is admitted very high. However, it is anticipated that the antenna will find most of its duty above 2 MHz. A 5% frequency change reduces the required capacitor value to well within the normal range for such components.

Table 16 provides the network component values for the next sub-band, 2.25-2.625 MHz. It uses the left-hand configuration of **Fig. 23**.

Table 16. Sub-Band 2 Components for Antenna A

Frequency MHz	X_{ant-L} μH	X_{sh-C} pF	X_{ser-C} pF	Approx. 50- Ω SWR
2.25	20.6	900	1600	1.9
2.375			500	1.1
2.5			270	1.2
2.625			175	1.5

The 20.6- μH series coil (X_{ant}) with a Q of 300 drops effective antenna gain by only 0.15-dB.

Table 17 provides the network component values for the next sub-band, 2.625-3.125 MHz. It uses the right -hand configuration of **Fig. 23**.

Table 17. Sub-Band 3 Components for Antenna A

Frequency MHz	Xant-C pF	Xsh-L* μH	Xser-C pF	Approx. 50-Ω SWR
2.625	200	---	2700	1.1
2.75			530	1.2
2.875			310	1.7
3.0			190	1.8
3.125			130	2.0

Note that sub-band 3 is 1 step wider than the previous sub-bands. The shunt inductor shows no value. The required reactance (and inductance) is so high that one may use any high-value (1 mH or greater) satisfies the network requirement. One may even omit the component.

Table 18 provides the network component values for the next sub-band, 3.125-3.5 MHz. It uses the right -hand configuration of **Fig. 23**.

Table 18. Sub-Band 4 Components for Antenna A

Frequency MHz	Xant-C pF	Xsh-L μH	Xser-C pF	Approx. 50-Ω SWR
3.125	130	12	1200	1.6
3.25			500	1.1
3.375			340	1.5
3.5			300	1.9

Although the shunt inductor appears large--and hence lossy--it actually yields very low network Q_s (Terman's Δ) and shows very little loss.

Table 19 provides the network component values for the next sub-band, 3.5-3.75 MHz. It uses the right -hand configuration of **Fig. 23**.

Table 19. Sub-Band 5 Components for Antenna A

Frequency MHz	Xant-C pF	Xsh-L μH	Xser-C pF	Approx. 50-Ω SWR
3.5	67.5	7.5	600	1.4
3.625			400	1.2
3.75			315	2.0

Using a slightly higher value for the Xsh inductor will reduce the maximum SWR value at 3.75 MHz. The values for Xser, a capacitor, will drop accordingly.

The goal of this design exercise is not to produce a final design for a matching system applied to the set of wide-band NVIS alternative inverted-V antennas. Rather, the exercise is an initial feasibility study to determine if the pre-tuning portion of the system can be reduced to a single component in the network. By modularizing the matching "box" into networks for individual

portions of each operating band of an antenna, the goal is achievable. Optimizing a usable system more properly falls within the expertise of an experienced network engineer in conjunction with those assigned to design the accompanying switching and software components.

The number of different modules in the present exercise is 5 per antenna to ensure tuning via one variable or stepped component per module. The use of one-variable-component tuning speeds the search and lock operation if the allowable 50- Ω SWR limit is 2:1. The number of different modules per antenna can be reduced to 3 by employing two sloping wires per inverted-V leg, with a spread of about 40°. Although each antenna thus requires 2 additional wires and wire-end tie-downs, patterns and gain are virtually unaffected. However, the fan sloped dipole has a reactance excursion rate of about 50% of the rate for the single-wire V. The result is somewhat simplified matching requirements, at least from the perspective of network design for a single variable component. As well, the Xant inductor used in the low range of each antenna creates about half the gain loss imposed by the large series inductor in the single-wire version of the system.

These notes on network possibilities conclude the work on the set of single-wire wide-band NVIS antennas that overcome the gain loss of terminated antennas. The exercise emerged from curiosity over what might be possible and what challenges might need to be met. In the initial exploration, the system does not overcome all challenges and hence has limitations that make its use improbable.

LBC
06-18-2005