Notes on 2-Band (2-M, 70-CM) LPDAs Part 2. Wide-Band LPDAs

L. B. Cebik, W4RNL (SK)

In Part 1 of these notes, we examined three LPDAs designed to cover the 2-meter and the 70-centimeter amateur bands. Unlike most notes on LPDAs, we placed the antennas in a vertical position relative to ground so that the H-plane of the array became the azimuth pattern. This orientation follows from the primary application of the beams to monitor FM simplex and repeater operations, virtually all of which employ vertically polarized antennas. We began with a minimal 5-element design using straight dipole elements. We then increased the element count to 13, first using straight elements and finally using V-dipoles with a 40° forward sweep. Our goal was to demonstrate in a stepped manner the improvements of better LPDA design and then to see both the advantages and disadvantages of using V-dipole elements.

As we expanded the size of the LPDA from an initial boom length of 24" up to a length of 36", we discovered—but did not show—that the design was capable of covering the entire upper-range span of 400 to 500 MHz. It is unlikely that an amateur in voluntary emergency service would need to cover frequencies above 470 MHz, since the upper region is allocated to television service. However, the fact that the 13-element arrays could cover the entire 70-cm band (420 to 450 MHz) plus the land mobile service allocations from 450 to 470 MHz might be a bonus in emergency service situations. Comparable low-range coverage might run from 125 to 175 MHz to encompass land, air, and maritime monitoring. However, the 13-element LPDA performance disappears below about 135 MHz.

We may re-design the LPDA for expanded low-range coverage. The critical additions involve the addition of 3 longer elements. Since the longer elements have the greatest impact on boom length, we can consider adding a few shorter elements to the front of the array. The shorter elements improve performance in terms of gain by permitting additional cycles of current peaks along the length of the boom at the highest operating frequencies in both ranges. In effect, these forward elements will be optional, and omitting the 4 forward elements of the array will occasion only a small cost in gain. In contrast, the 3 new elements to the rear are necessary for expanded coverage down to 125 MHz. As we shall discover, however, these longer elements will exact a small price in upper-range performance.

The Evolution of the 20-Element LPDA

Although we may loosely speak of the 20-element design as adding elements fore and aft of the 13-element design that we examined in Part 1, the essential design process must adhere to the applicable LPDA design principles. For a 2-band array, we must select values of τ and σ that promise effective performance in both ranges. The elements will operate in the lower range in the $\frac{1}{2}\text{-}\lambda$ mode, that is, where each element forms a standard $\frac{1}{2}\text{-}\lambda$ dipole at a design frequency within the LPDA design span. The design range for the low-range is the first step in the process. The 20-element array that we shall examine covers 125-175 MHz, with additional elements such that the shortest is self-resonant at a frequency about 1.6 times the highest operating frequency. The use of the additional elements above the highest operating frequency ensures relatively smooth performance levels within the operating range.

LPDAs do not operate effectively when the elements are in a mode that represents an even number of half wavelengths. Therefore, the second operating range requires that the elements use the $\frac{3}{2}\text{-}\lambda$ mode. In this mode, each element operates as 3 half-wavelength elements,

resulting in relatively low self-resonant impedance—but not as low as the impedance at self-resonance in the $\frac{1}{2}\lambda$ mode. In an LPDA design, we must also select a low-range value for σ that is low enough so that in the upper frequency range, the value does not exceed the optimal value of σ for each half-wavelength of the elements. Therefore, adequate performance on each range tends to require a high value for τ and a low initial value for σ . For the design example that we shall explore, the values are $\tau = 0.956$ and $\sigma = 0.0446$. With 1/8" (0.125") elements, we obtain the dimensions shown in **Table 1**.

Table 1. Dimensions for a 20-element 2-band/wide-band LPDA with straight elements

Element diameter = 0.125", $\tau = 0.956$, $\sigma = 0.0446$, phase-line = 80 Ω

El. No.	Total Length	Space from rear
1	48.21"	0"
2	46.09	4.30
3	44.06	8.42
4	42.14	12.36
5	40.26	16.12
6	38.50	19.71
7	36.00	23.15
8	35.18	26.44
9	33.63	29.58
10	32.15	32.58
11	30.74	35.45
12	29.38	38.20
13	28.10	40.82
14	26.86	43.33
15	25.68	45.73
16	24.54	48.02
17	23.46	50.22
18	22.43	52.31
19	21.45	54.31
20	20.50	56.23

The elements will apply to all of the variations of the basic LPDA that we shall examine. Note that the boom length is less than 5'. As we eventually convert straight elements to a V-configuration, the element tips will move forward, extending the total length of the array to a maximum of 62" with a 40° sweep.

Although the rule of thumb for 2-band operation is a 3:1 frequency ratio, the ratio is not precise. We can find many reasons for the imprecision. Ideally, LPDA element diameters should be stepped so that there is a constant length-to-diameter ratio. Normal LPDA construction for the VHF and UHF ranges tends to use elements with a constant diameter and hence, a variable length-to-diameter ratio. Moreover, the elements have only two free ends. Therefore, the self-resonant frequencies of individual elements do not show a precise 3:1 ratio for any element with a diameter that is greater than infinitesimal. Because the element lengths may operate in different modes along the length of a large LPDA, the upper frequency region of effective operation is normally narrower than 3 times the lower-range of effective operation. (We shall examine a specific case of multi-mode operation before we have completed our examination.)

In addition to these design considerations, sweeping elements forward in a V-configuration is subject to a number of variables. In fact, it is worth our efforts to compare performance values for several configurations, including the use of straight dipoles and forward sweeps of several possible angles. **Fig. 1** outlines the collection of design options that we can usefully explore. The selection of sweep angles from 30° to 40° is not accidental.

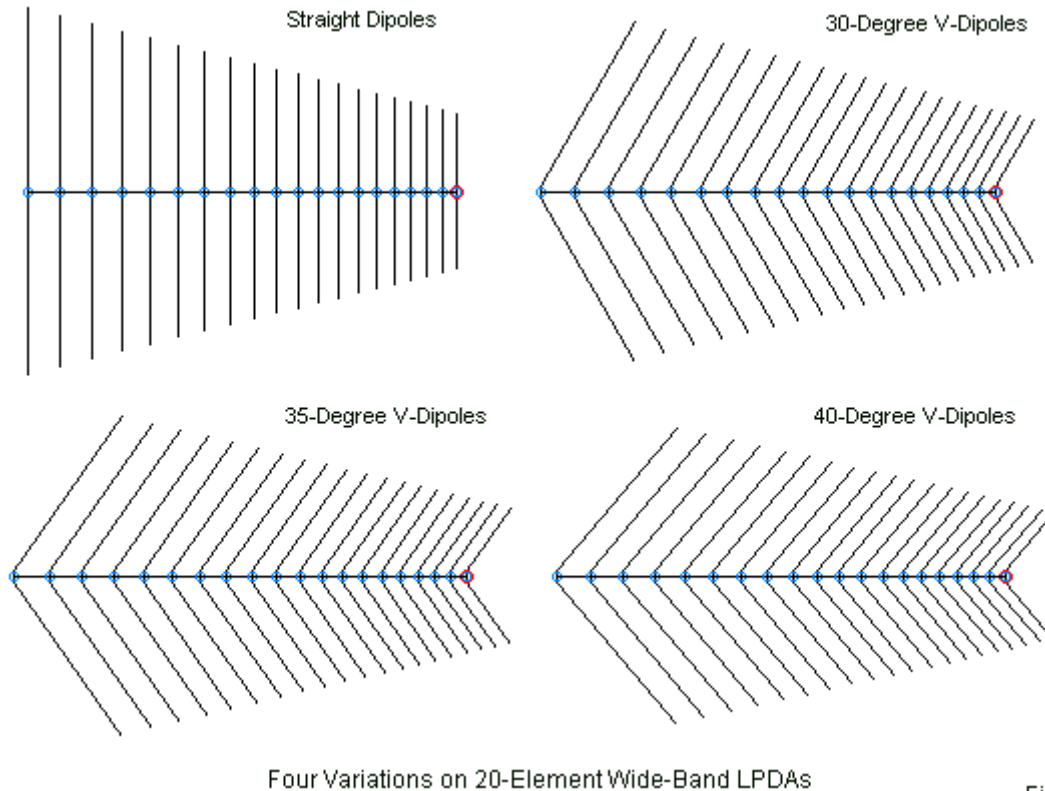

Fig. 1

Since the outlines are to scale, the sketches show to what degree a V-configuration extends the total array length and shrinks the tip-to-tip width. Below about 30°, the upper-range performance suffers because the 3-lobe forward pattern of the straight dipoles does not merge into a single main lobe. Side lobes remain, and increasing the sweep angle tends to reduce their strength, but at increasing costs in low-range forward gain.

We may view the low-range (125-175 MHz) gain situation in both tabular and graphic forms by looking at **Table 2** and **Fig. 2**. Each curve in the comparative-gain graph shows a set of values with a very small range from maximum to minimum. As we increase the sweep angle of the V-elements, the average gain decreases. The decrease is the cost of having an effective 2-band LPDA. Between straight elements and elements with a 40° forward sweep we lose an average of about 1 dB of forward gain in the lower operating range.

As the table suggests, we do not lose any significant performance with respect to the front-to-back ratio. Ratios above 25 dB are not distinguishable from each other, and the lowest recorded value is close to 26 dB. (Of course, the values are for the 180° front-to-back value, and the worst-case value for the array is closer to about 20 dB, still a very good performance figure.)

In addition, the tabular data indicate that we do not suffer any harmful effects with respect to the feedpoint impedance in the lower range. The SWR values use a reference value of 75 Ω. The low-range impedance values present very low 50-Ω SWR values, but the upper range will require the higher characteristic impedance for the main feedline. Surplus hard-line is an inexpensive means of obtaining low line losses in the VHF and UHF regions.

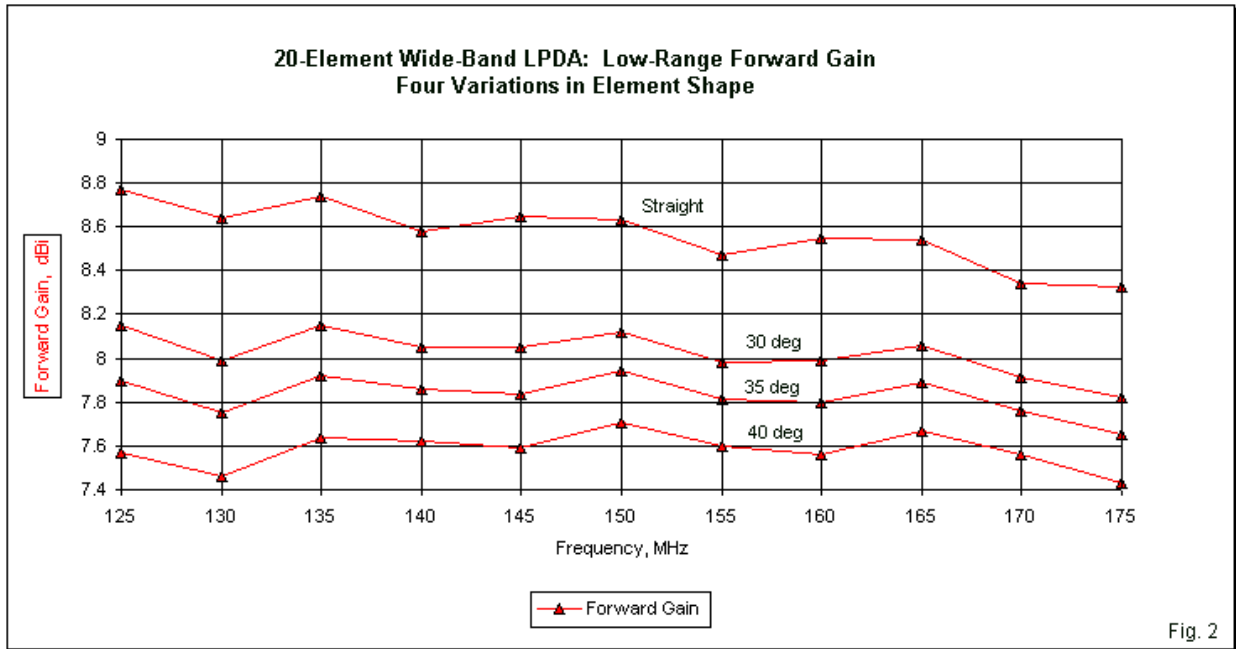

Fig. 2

Table 2. Performance of four variations of the 20-element LPDA in the low range (125-175 MHz): environment = free space

Freq. MHz	Gain dBi	F-B Ratio dB	H-plane BW deg	E-Plane BW deg	Impedance R +/- jX Ω	75-Ω SWR
Straight Dipole Elements						
125	8.77	28.63	91	61	46.5 – j1.9	1.61
150	8.63	33.63	92	62	50.3 – j5.4	1.51
175	8.33	29.48	96	62	55.4 – j2.3	1.36
V-Dipoles, 30°						
125	8.15	30.73	98	67	48.8 – j4.0	1.54
150	8.12	36.53	98	67	50.8 – j4.1	1.48
175	7.82	31.58	103	68	49.5 + j1.3	1.52
V-Dipoles, 35°						
125	7.90	30.17	101	70	50.7 – j4.4	1.49
150	7.94	33.43	100	69	51.2 – j3.0	1.47
175	7.65	34.25	106	70	48.2 + j0.8	1.56
V-Dipoles, 40°						
125	7.57	25.94	105	72	53.4 – j4.1	1.41
150	7.71	29.67	103	71	51.2 – j1.1	1.47
175	7.43	41.82	109	73	47.7 + j0.1	1.57

As we noted in Part 1, a second cost of using V-configuration elements is an increase in the E-plane and H-plane beamwidths. The tabular data clearly indicate the slow but steady growth of these values as the sweep angle increases.

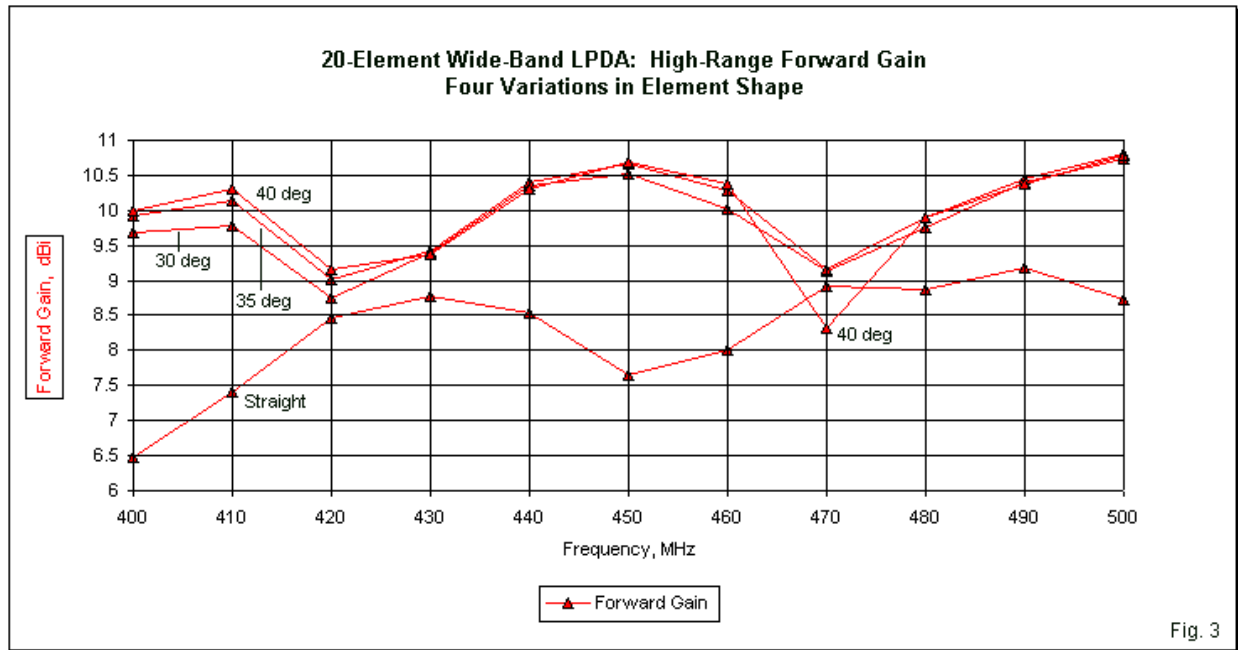

Fig. 3

Table 3. Performance of four variations of the 20-element LPDA in the high range (400-500 MHz): environment = free space

Freq. MHz	Gain dBi	F-B Ratio dB	H-plane BW deg	E-Plane BW deg	Impedance R +/- jX Ω	75-Ω SWR
Straight Dipole Elements						
400	8.90*	25.34	116	33	74.0 + j55.1	2.06
450	7.66*	24.89	119	28	91.3 + j3.0	1.22
500	8.73*	32.06	114	21	89.0 + j6.2	1.21
V-Dipoles, 30°						
400	9.69	15.33	91	29	83.9 + j48.4	1.84
450	10.52	28.78	82	28	91.7 + j2.9	1.22
500	10.73	29.74	72	27	92.8 + j4.6	1.25
V-Dipoles, 35°						
400	9.92	15.49	87	30	87.0 + j48.2	1.83
450	10.67	28.82	81	29	92.4 + j3.0	1.24
500	10.82	30.42	71	28	93.8 + j4.8	1.26
V-Dipoles, 40°						
400	10.00	15.89	85	31	90.0 + j48.9	1.85
450	10.68	29.06	81	31	93.7 + j3.4	1.25
500	10.78	31.15	72	30	95.1 + j5.4	1.28

Note: * indicates that the pattern has three lobes, and the strongest lobe may not be straight forward.

Fig. 3 and **Table 3** provide comparable information for the upper frequency (400-500 MHz) range of operation. In this region, the difference in gain performance favors the collection of V-element configurations, largely due to the fact that the E-plane pattern of the straight-element LPDA has three distinct lobes of nearly equal strength. The reported E-plane beamwidths in the table for this LPDA simply record the beamwidth of the strongest lobe, which may not always be the lobe in line with the axis of the beam.

The H-plane beamwidth, which becomes the azimuth pattern of the array when used vertically over ground, is very wide when we use straight elements. Part 1 showed patterns for the 13-element LPDA that are similar to those of the present 20-element version. The patterns show maximum strength along the H-plane axis, but the very wide beamwidth results in lower forward gain compared to the group of V-dipole LPDAs.

Because the gain curves for the straight and V-element versions of the LPDA have such different shapes, the gain differential is highly variable across the upper frequency range. However, all three V-elements show very similar maximum forward gain values with only small differences in the E-plane and H-plane beamwidth values as we sweep the elements forward from 30° to 40°. The 40° version has slightly higher gain at the low end of the range, but shows the greatest drop in gain of the three at 470 MHz. We shall return to this drop in gain after we explore further data about the array in both frequency ranges.

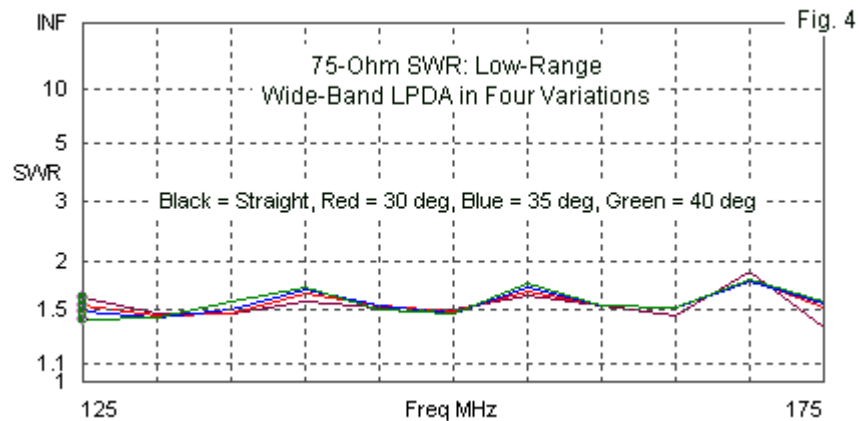
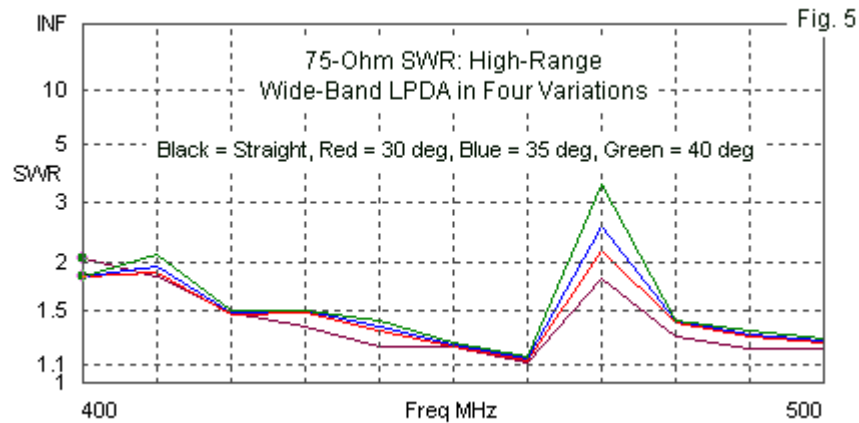

Fig. 4 provides the SWR curves for all four versions of the LPDA from 125 to 175 MHz. The reference impedance is 75 Ω, even though the low-range values in the table appear to favor a 50-Ω standard. The use of 80-Ω phase line impedance provides the lower range with near-50-Ω impedance values. If one used the array only on the lower band, then I would recommend use of straight elements and a 50-Ω feedline. However, for dual-band use, a 75-Ω feedline represents the best compromise value.

In **Fig. 5**, we can see some of the reason for the recommendation. The SWR values shown in this graph reflect feedpoint impedances that run from about 75 Ω to nearly 100 Ω. The sample data in **Table 3** show the small spread of values for any one version of the array. In fact, we should always expect the impedance values on the higher band to be greater than the values for the lower band. The use of phasing techniques to feed the array tends to reduce the differential in impedance at self-resonance between the $\frac{1}{2}\lambda$ mode and the $\frac{3}{2}\lambda$ mode, but some difference will remain in practical LPDAs that use both modes.



The upper band 75-Ω SWR curves are quite similar, even for the straight-element version of the array. The lowest recommended frequency of use falls between 410 and 415 MHz, although the small excursion of the SWR above 2:1 at the low end of the range will not hurt reception. An anomalous value appears at 470 MHz, coinciding with the drop in gain at the same frequency that we saw in **Fig. 3**. The anomaly actually is about 2 MHz wide and peaks at 470 MHz. Although the chart records values to 500 MHz, actual amateur and related uses of the array would normally cut off at about 470 MHz, which is the dividing point between land-mobile service below this frequency and television channels above it. Therefore, the anomaly is unlikely to create any difficulties in actual use of the array.

Fig. 6 provides us with an account of what happens to the array at 470 MHz by comparing the relative current magnitude distribution at that frequency with the distribution at both 450 and 490 MHz. Above and below the anomalous frequency, the rear elements are relatively quiescent. (When we operate an LPDA in the $3/2\text{-}\lambda$ mode, the rear elements are never as quiescent as when we operate the same array in the $1/2\text{-}\lambda$ mode.) At 470 MHz, we see considerable rear-element current activity, while the forward-most elements show a lower level of current than we see on the other sampled frequencies. For clarity in tracing the current magnitude curves, I have rotated the LPDA model by 90°.

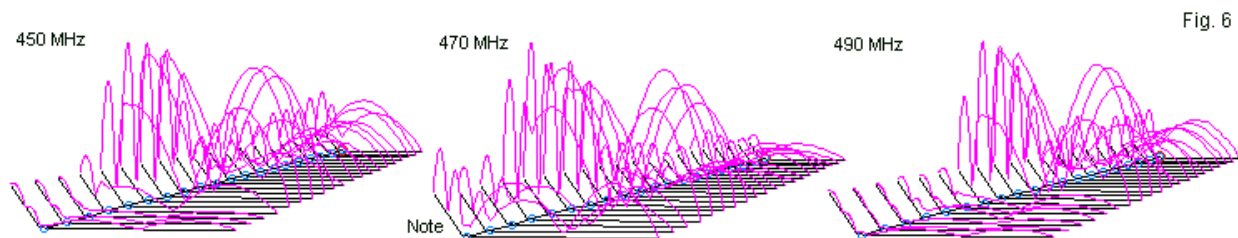

Relative Current Magnitude Distribution on the 40-Degree V-Dipole 20-Element LPDA at 3 Frequencies

At 470 MHz, the LPDA is operating simultaneously in 3 different modes: $2/2\text{-}\lambda$ on the shortest elements, $3/2\text{-}\lambda$ in the most active region, and $4/2\text{-}\lambda$ on the rear elements. The rear elements are sufficiently active to direct a significant portion of the radiation rearward and to disrupt the normal feedpoint impedance at the anomalous frequency. **Table 4** provides a snapshot of the free-space values at the three sample frequencies shown in **Fig. 6**.

Table 4. Performance of the 20-element LPDA with 40° V-dipoles at 450, 470, and 490 MHz in free space

Freq. MHz	Gain dBi	F-B Ratio dB	H-plane BW deg	E-Plane BW deg	Impedance R +/- jX Ω	75-Ω SWR
450	10.68	29.06	81	31	93.7 + j3.4	1.25
470	8.31	4.91	93	31	32.3 + j49.1	3.46
490	10.38	37.40	80	29	96.3 + j12.2	1.33

The root sources of the anomaly are a combination of two factors. One factor is the addition of the three rearward elements that we added to the 13-element LPDA shown in Part 1. These elements are long enough to permit operation in the $4/2\lambda$ mode at one or more frequencies in the upper range of the LPDA. For these elements to be active, the current phase at their feedpoint (that is, their connections with the phase line) must be correct, and this condition generally occurs at a single frequency (or more correctly, a very narrow range of frequencies). Normally, this condition does not occur with high-impedance phase lines. However, this design has selected a low-impedance line, a selection based on the prospect of using double-boom construction in which the twin booms also form the phase line. Redesigning the array for a higher impedance line—perhaps in the 200-Ω region—would remove the anomaly but require elements that are insulated from the boom and a separate phase-line assembly, not to mention very wide-band impedance transformer at the feedpoint, if we wish to use coaxial cable for the main feedline. Since the anomaly is not fatal to the intended use of the LPDA, we may live with it. However, others may wish to redesign the LPDA to eliminate the anomaly.

One reason for selecting the 40° V-element version of the LPDA, despite the fact that it shows the anomaly at greatest strength, lies in the E-plane patterns. **Fig. 7** shows the patterns for all four variations of the LPDA at the frequencies sampled in the basic data table. The 3-lobe patterns of the straight-element version clearly show the resulting lower gain derived from this configuration. In contrast, all of the V-dipole versions show the merging of the 3 lobes into a main lobe with 2 side lobes. The greater the sweep angle, the smaller the side lobes become, even though in the range of V-angles shown, there is no significant difference in forward gain. Further increases in the V-angle would result in lower gain values.

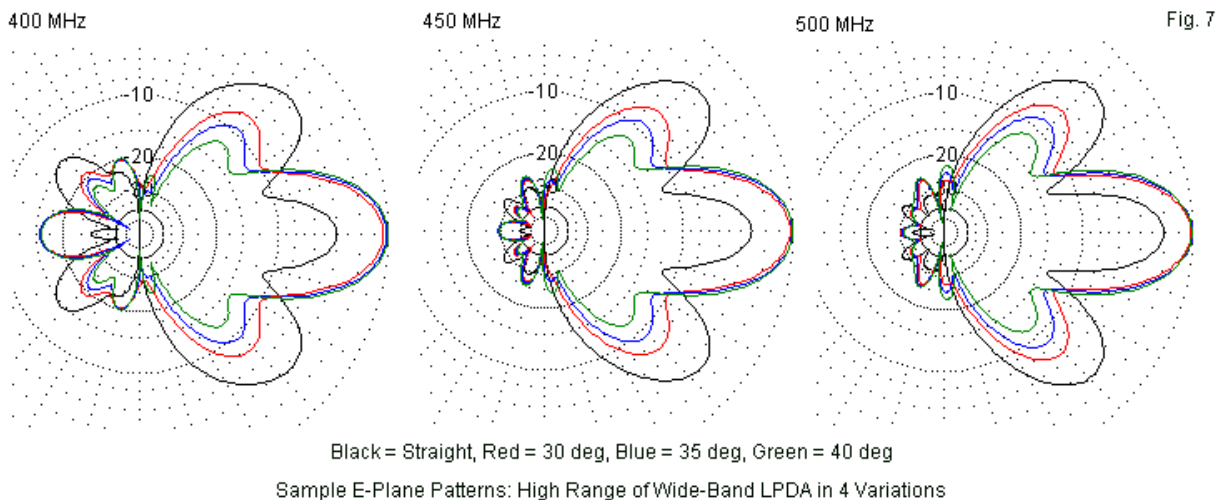

One beneficial consequence of using a 40° V-angle is to reduce the high-angle radiation that serves no useful communications function in the higher frequency range of the array. If we place the array 20' above average ground and create an elevation pattern, the difference becomes more vividly apparent. **Fig. 8** overlays the 440-MHz elevation patterns for the straight-element and the 40° V-dipole versions of the LPDA. The advantages of the V-dipole array become instantly clear.

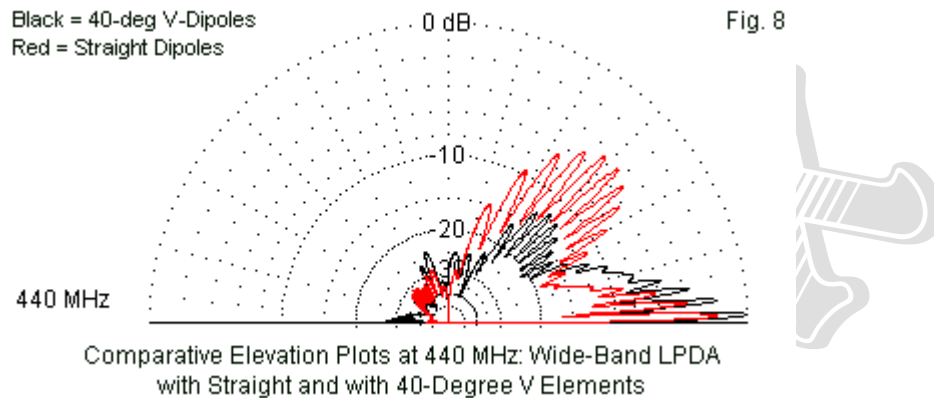

Practical Operation and Structure

Before we close the book on the 20-element wide-band LPDA with 40° V-dipoles, we should look at its performance over ground. Specifically, we shall place the antenna 20' over average ground (conductivity 0.005 S/m, permittivity 13), as we did for the antennas in Part 1 of these notes. **Table 5** provides sample wide-band data for both frequency ranges.

Table 5. Wide-band performance of the 20-element LPDA 20' above average ground (conductivity 0.005 S/m, permittivity 13)

40° V-dipole elements, element diameter = 0.125", $\tau = 0.956$, $\sigma = 0.0446$, phase-line = 80 Ω

Freq. MHz	Gain dBi	TO Angle degrees	F-B Ratio dB	H-plane BW deg	Impedance R +/- jX Ω	75- Ω SWR
Low-Range						
125	10.94	4.9	26.10	105	53.4 - j4.2	1.41
150	11.46	4.2	29.62	103	51.3 - j1.2	1.46
175	11.47	3.6	41.25	109	47.7 + j0.1	1.57
High-Range						
400	15.06	1.7	15.90	85	90.0 + j48.9	1.85
450	15.85	1.5	29.09	81	93.7 + j3.4	1.25
500	16.01	1.3	31.16	73	95.1 + j5.4	1.28

Compared to the 13-element LPDA with a similar element sweep, the larger array provides about 1 dB additional forward gain, with a consistently high front-to-back ratio (except at the low end of the upper range). The impedance and SWR values are not significantly different from the free-space values. The TO angle is the take-off angle or elevation angle of maximum field strength. The values are fully consistent with other vertically oriented directional arrays.

We may also look more closely at the performance within the 2-m and the 70-cm amateur bands. **Table 6** provides the data for the limits and the middle of each band.

Table 6. Amateur-band performance of the 20-element LPDA 20' above average ground (conductivity 0.005 S/m, permittivity 13)

40° V-dipole elements, element diameter = 0.125", $\tau = 0.956$, $\sigma = 0.0446$, phase-line = 80 Ω

Freq. MHz	Gain dBi	TO Angle degrees	F-B Ratio dB	H-plane BW deg	Impedance R +/- jX Ω	75- Ω SWR
2-Meters						
144	11.24	4.3	29.64	106	52.2 - j2.4	1.44
146	11.31	4.3	32.74	105	47.0 - j5.4	1.61
148	11.40	4.2	31.98	104	46.0 - j0.4	1.63
70 Centimeters						
420	14.26	1.6	28.23	115	107.7 - j17.7	1.51
435	14.96	1.5	25.79	118	108.2 + j16.6	1.51
450	15.85	1.5	29.09	81	93.7 + j3.4	1.25

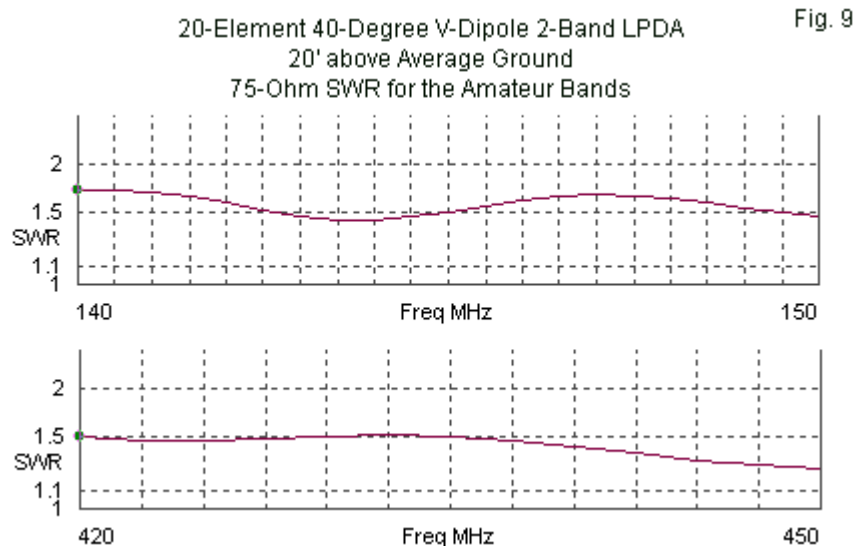

Fig. 9 maps the 75- Ω SWR values over both amateur bands. I have expanded the lower band limits for the sake of CAP and other operations that may occur near but not within the amateur allocation. Just as in the wide-band data, the lower range impedance values tend to favor a 50- Ω main feedline, but the higher-range impedance values are closer to 100 Ω . Therefore, a 75- Ω main feedline represents the best compromise.

Fig. 10 and **Fig. 11** provide more detailed sweep information for the forward gain and the 180° front-to-back figures that emerge from the array model. In general, the variations in values across the amateur bands are relatively small, although the upper band shows an increasing gain value with increasing frequency. Gain is highest in the FM/repeater region of the 70-cm band. Although the curve for the 2-m band is similar over the 10-MHz span of the sweep, the values on the X-axis show that the total increase is less than 0.25 dB. In contrast, the range of variation on the 70-cm band is closer to about 1.6 dB.

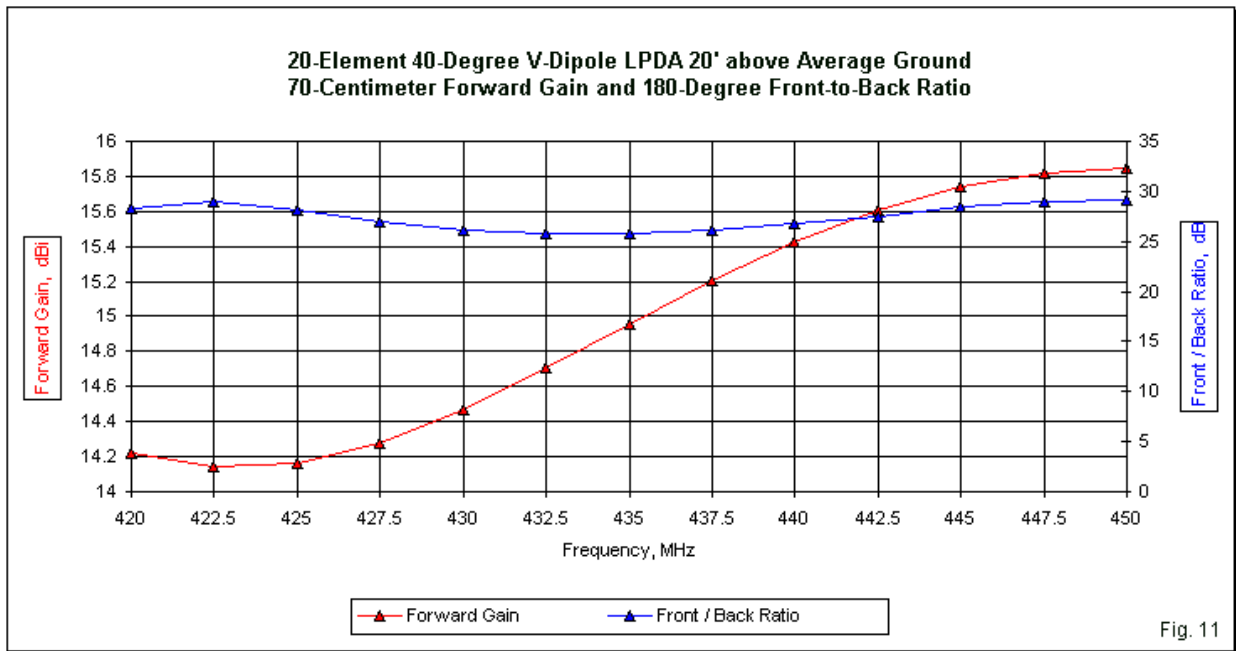
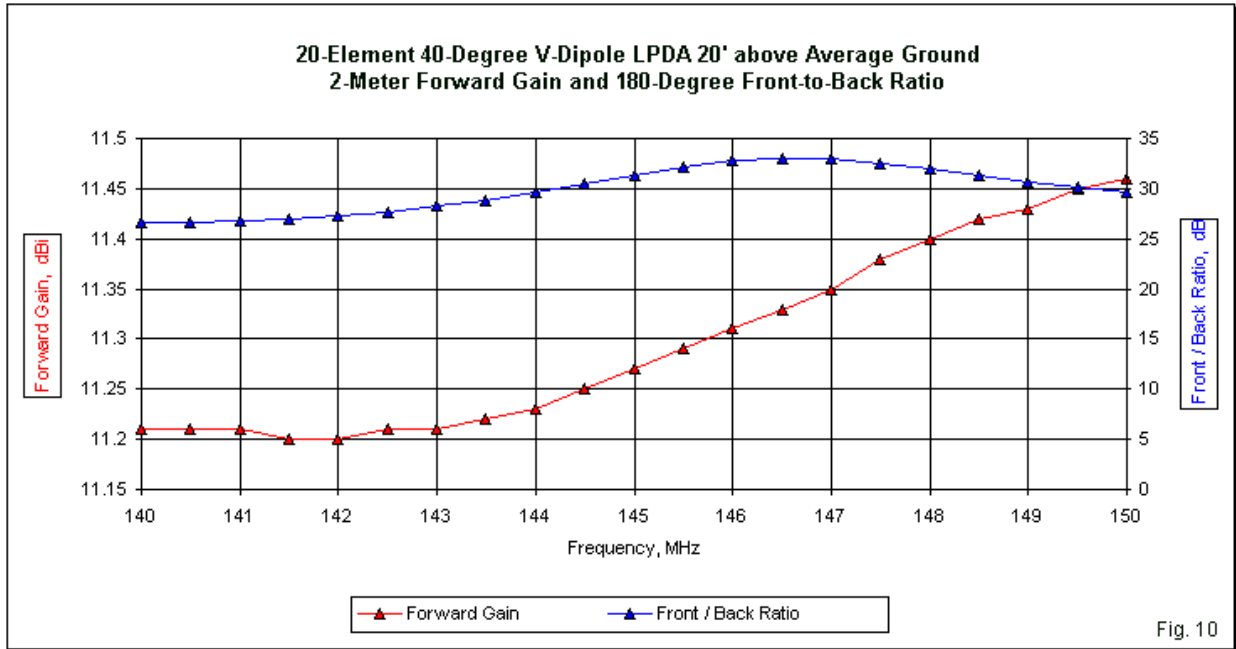
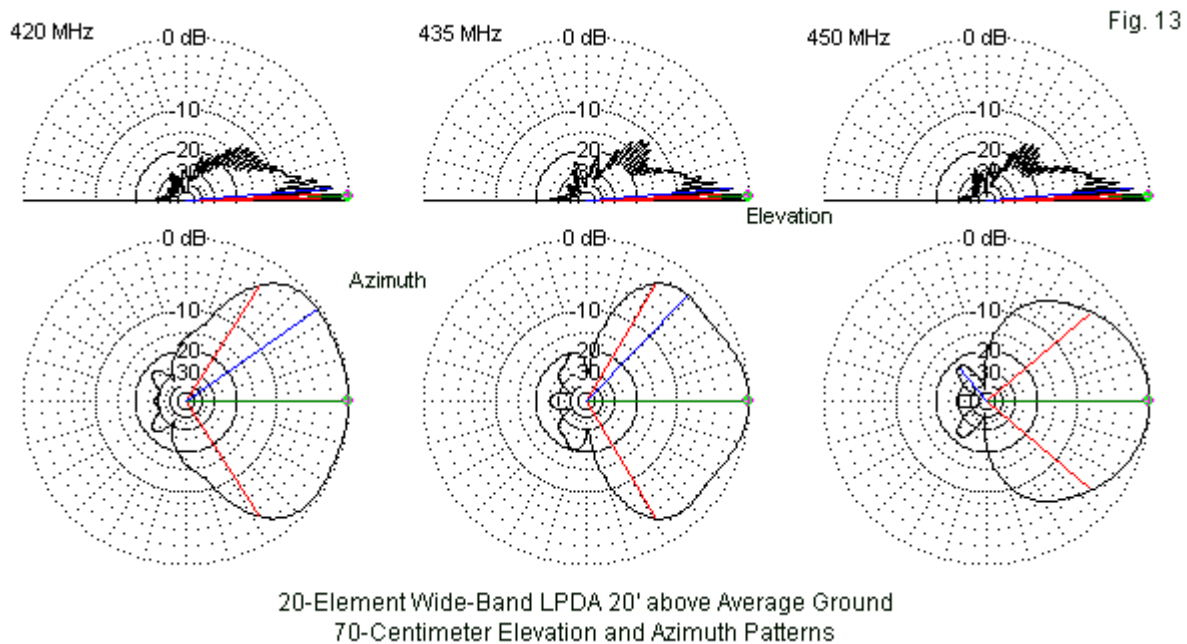
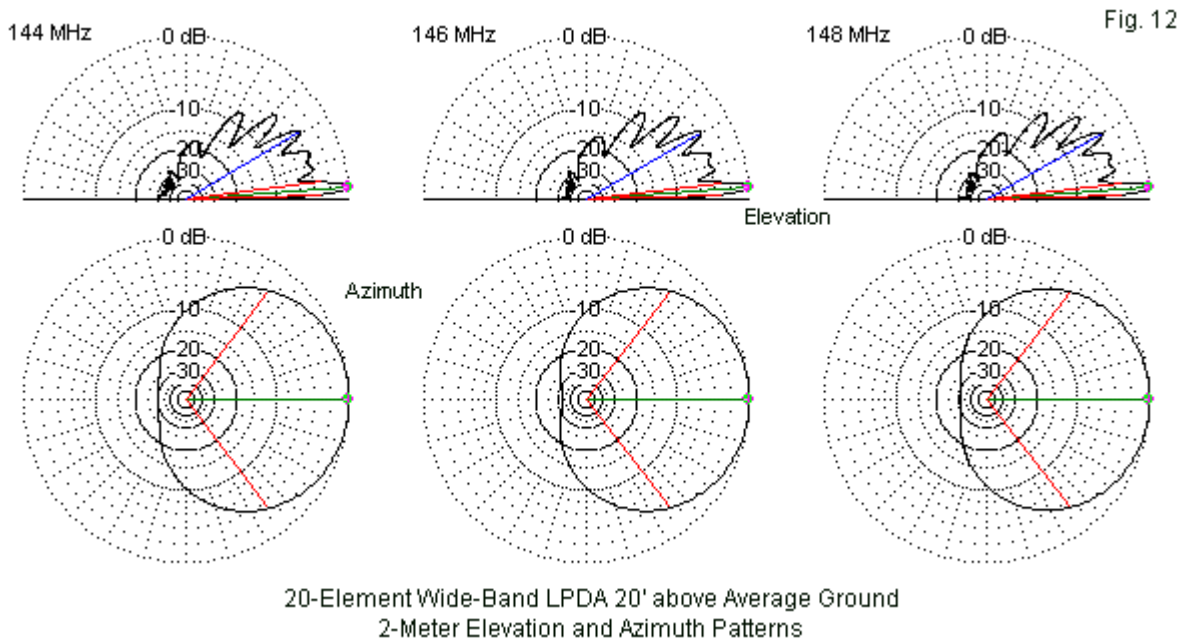

Fig. 12 and **Fig. 13** provide galleries of elevation and azimuth patterns for the two amateur bands. The shapes of the 2-meter patterns are very similar to those surveyed with smaller LPDAs in Part 1. Only the gain and front-to-back values differ from the earlier models. Because the 70-cm patterns cover the entire band and not just the upper 10 MHz shown for the Part-1 models, we may obtain a better understanding of $3/2\text{-}\lambda$ -mode operation. The azimuth patterns show variations in the overall shape of the forward lobe. All of the patterns are highly usable and no hindrance to any operation. In fact, the variations do not radically alter the H-plane beamwidth over ground. Therefore, while interesting in revealing some of the variability of

H-plane pattern shape when we operate an array in the 3.2λ mode, the patterns are otherwise operationally equivalent.



The array as designed requires a dual boom that also serves as the phase line for the LPDA. As we earlier noted, it is possible to redesign the array for a higher value of phase-line characteristic impedance. However, except for television antennas, VHF and UHF LPDAs tend to use twin-boom construction. For phase-line impedance values of $80\text{-}\Omega$ or lower, we require facing flat surfaces to arrive at the desired impedance. Round conductors tend to interpenetrate at impedance values of about $80\text{ }\Omega$. Flat surfaces provide for lower impedances before

touching. We may use either U-channel or square stock to form the booms and lines. **Fig. 14** provides a simple sketch of the general properties of the assembly.

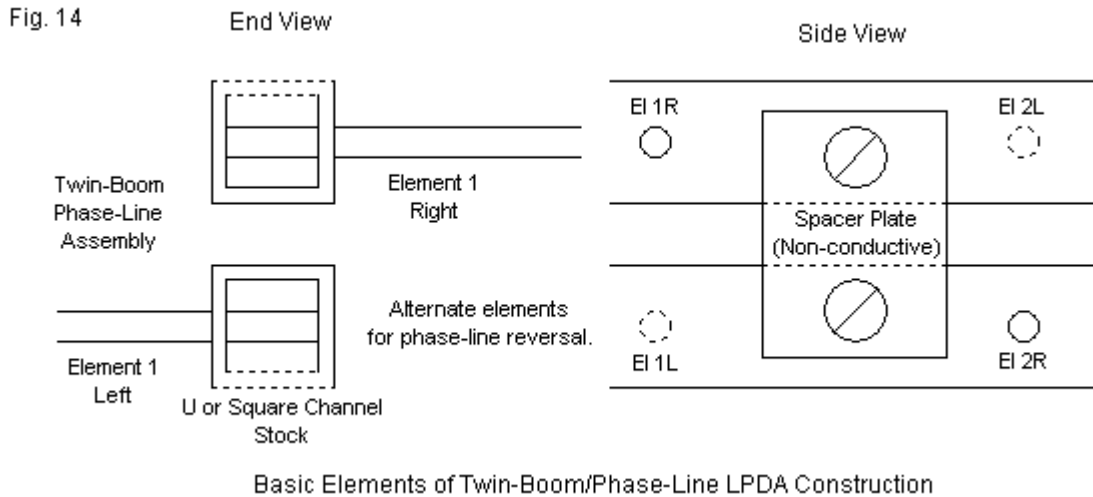

The spacing between the flat surfaces determines the line impedance. **Table 7** provides a brief listing of the required gap between surfaces to arrive at either 75 Ω or 80 Ω. (The 5-element LPDA in Part 1 used a 75-Ω line.) Note that the required spacing is roughly proportional to the width of the facing surfaces.

Table 7. Spacing between flat (square/U-channel) conductor to achieve 75-Ω and 80-Ω characteristic impedance values

Conductor Width (inches)	Required Gap (inches)	Desired Characteristic Impedance	
		75 Ω	80 Ω
0.5"		0.184"	0.204"
0.75"		0.276"	0.305"
1.00"		0.368"	0.407"

Each phase line at each element position holds half of one element. Measure the half element to the centerline of the phase-line stock. If the mounting method requires the element to penetrate a hole in both sides of the stock, add half the width of the phase line to the half-element length. One commercial method of mounting the element heats the phase line to enlarge precisely drilled holes. It also chills the element end to reduce its diameter. Once positioned, the assembly returns to a normal temperature, locking the element in place. You may bend the element forward either before or after mounting them in the boom. A custom bending-jig is a must to ensure that all elements bend to the same angle and remain on the same plane after bending. As the right side of the sketch shows, the elements alternate booms to achieve the required line reversal from one element to the next.

Conclusion

In Part 1, we surveyed several LPDA designs for vertically oriented service on the amateur 2-meter and 70-centimeter bands. We observed the shortcomings of using straight elements in the 3/2-λ mode required for the higher frequency range. As well, we saw the trade-offs required when using V-dipole elements in terms of a slight gain loss on the lower band and increased

gain and pattern control on the upper band. We also noticed that the 13-element V-LPDA was capable of covering the entire 70-cm band and more.

To overcome the lower frequency cut-off of the array on the lower range of operation, we increased the element count, adding 3 longer rear elements. The result gave us effective operation from 125 to 175 MHz, allowing use of the array for monitoring all services in the frequency span. Adding a few short elements to the array's front end improved performance without adding significant weight or length to the beam. In this part of the notes, we more fully explored the effects of using different V-angles. The 40° V-angle yielded close to maximum possible gain with the smallest side lobes in the E-plane. Adding the longer rear elements and using the 40° angle did allow the appearance of an anomalous frequency at about 470 MHz, which marks the limit of use for monitoring 2-way services in the upper frequency range. The anomaly is not only a function of the longer rear elements, but as well results from the use of a low phase-line impedance value, necessary for twin-boom construction.

Although the array described in these notes is feasible as a construction project, its main task has been to illustrate the principles of two-band LPDAs using the amateur bands as a focus. The 2-m and 70-cm bands have the correct 3:1 frequency ratio to achieve the goal of 2-band operation. The question then becomes a matter of finding an LPDA design that gives the best compromise operation on each of the bands. Hopefully, these notes have provided some ideas that may assist in making that decision.

**© All Rights Reserved World Wide
ANTENNEX LLC**