

---

# Designing Multi-Band Parasitic Beams

## Part 1: General Design Considerations

L. B. Cebik, W4RNL (SK)

---

The design of a multi-band parasitic beam displays artistry, science, and craftsmanship that should engender admiration of the designers, whether a beam emerges from a team effort or from the labors of an individual. Modern designs have set aside traps in favor of larger collections of individual elements. We shall not here debate the relative merits of one design over another. Rather, these notes will try to encapsulate some of the considerations that go into effective multi-band beam design. We shall focus on design factors affecting beams with linear elements, since multi-band quad design raises quite different versions of the critical factors involved.

Too many adventuresome novices in the antenna arena try to slap together two monoband beams, interlacing them on the same boom. Then they wonder why neither beam performs as well as it did when on its dedicated boom. The task of creating a multi-band beam, especially one using a common feedpoint for all bands covered, is far different from just interlacing a set of elements. It requires an understanding of the consequences of placing elements for different bands in relatively close proximity. Even with that understanding, the development of an adequate design may still require considerable trial and error. Once, all of the adjustments to element length and position required the manipulation of physical elements on a range. Today, 95% of the adjustments occur using antenna modeling software, with the final 5% performed on the actual prototype to account for construction variables that models do not take into account. Whatever the savings in labor that computer modeling accrues, successful new designs do not emerge overnight.

Let's divide these notes into two efforts. In this section, we shall examine the background necessary for successful design of a relatively simple 2-band parasitic beam. There will be nothing completely new in these notes, but the compilation may be useful to those just beginning to give vent to the urge to design one's own multi-band beam. In parts 2, 3, and 4, we shall explore two different types of beams that cover 15 and 10 meters as examples of the principles in action. No part will cover exhaustively every option and possibility, but the points that we do cover will underlie most multi-band beams. You may have already noted that I have not yet used the term *Yagi* in this introduction. The void is intentional, since one of the examples in Part 2 will make use of a Moxon rectangle for one band. That type of antenna is a parasitic beam, but not a true Yagi.

### *Expectations*

The first step in multi-band beam design consists of understanding monoband beam designs well enough to have reasonable expectations of the final product. The most common monoband parasitic beams used as the building blocks of a multi-band beam are the driver-reflector 2-element Yagi and the 3-element Yagi. These beams bring with them very different performance expectations. The outlines and patterns in **Fig. 1** only sample some of the differences.

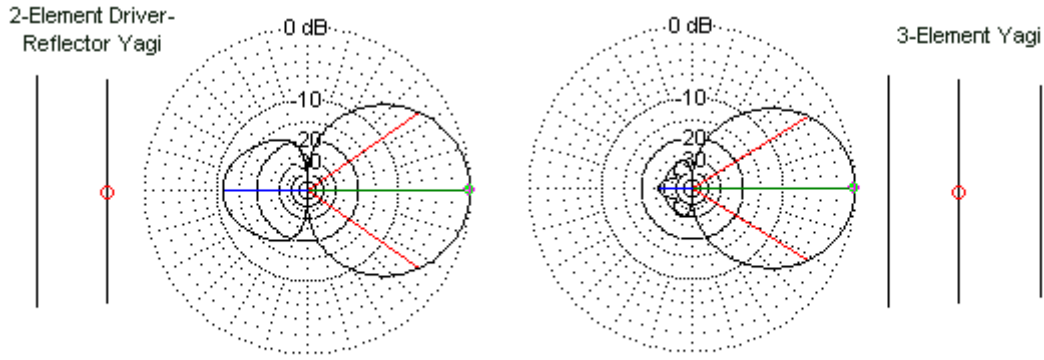

Free-Space E-Plane Patterns: Typical Monoband Yagis

Fig. 1

One reason for use a driver and reflector in a 2-element array is that we achieve a greater operating bandwidth than we can obtain from a driver-director model. We may be able to design a driver-director Yagi with up to a full dB more gain and 5-8-dB higher front-to-back ratio, but that peak performance might cover only about 1/4 to 1/3 of one of the wider upper HF bands. The other price that we pay for the added gain is a very low feedpoint impedance. Such designs are better suited to the narrower 30-, 17-, and 12-meter bands. In contrast, we can construct a wide-band driver-reflector 2-element Yagi with a 50-Ohm impedance and cover all of the first MHz of 10 meters with relatively equal gain and front-to-back ratio. However, the gain and front-to-back numbers will be modest, as shown by the curves for a sample version of the 2-element antenna in **Fig. 2**.

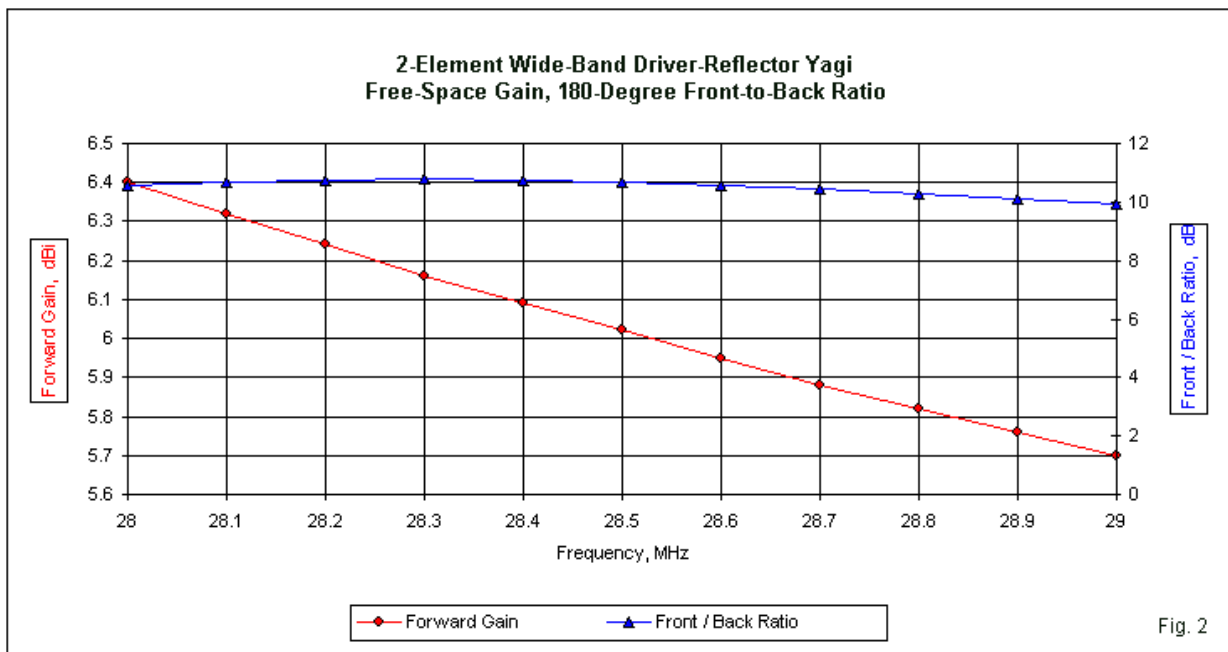

Fig. 2

Like all driver-reflector 2-element arrays, the Yagi shows a declining gain with increasing frequency. The front-to-back ratio is almost constant in this relatively wide-spaced version (about 0.15-λ). The ratio will increase if we close the spacing and reduce the feedpoint impedance. At about 0.125-λ spacing, the beam would have about 1-2-dB added front-to-back

ratio, but the gain would not increase significantly. Despite these modest figures, the driver-reflector 2-element Yagi is highly serviceable.

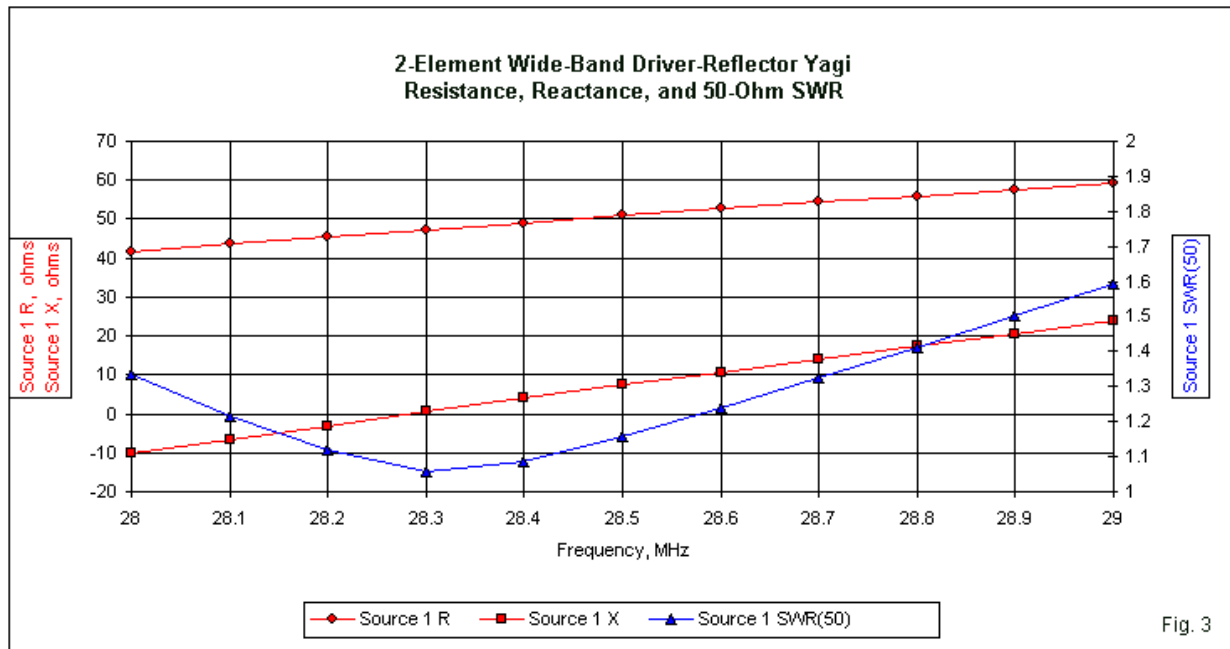

Fig. 3

Despite the fact that this sample does not place the minimum 50-Ω SWR at mid-band, the value rises only to about 1.6:1 at the upper end of the band, as shown in **Fig. 3**. The rates of change of both the feedpoint resistance and reactance are close to the same and quite modest. Therefore, the design is relatively uncritical of small construction variables.

A three element Yagi with both a reflector and a director has quite different characteristics. The presence of a director is the chief source of the differences. Not only does the director improve forward gain, but it also is largely responsible for the improved front-to-back figure, as evidenced in the initial pattern for this arrangement. Some arrays with multiple directors have dispensed with the reflector altogether with only a small loss of performance. The reflector length and spacing from the driver tends to set the feedpoint impedance and to broaden the operating bandwidth, especially at the lower end of the range. Most well designed 3-element Yagis will have free-space E-plane patterns like the sample, although the numbers that we attach to the patterns cover a very wide range.

If we are willing to accept a feedpoint impedance between 20 and 25 Ω, then the boom length will largely determine the gain. A total boom length of less than 0.25-λ (about 8' on 10 meters) will yield a design frequency gain of just over 7 dBi in free space. As the boom length approaches 0.35-λ (about 12' on 10 meters) the gain increases to about 8 dBi in free space. For either length or lengths in between, we can so structure the elements to achieve about 20 dB front-to-back ratio and have that figure hold over the first MHz of 10 meters and easily over the other wide upper HF bands.

If we desire a feedpoint impedance closer to 50 Ω, we must rearrange the elements, using a much wider driver-to-reflector spacing. For a boom length close to 0.35-λ, the array loses about 1 dB of gain relative to the lower impedance version of the same length, but the beam requires

no matching network for connection to a 50-Ω source. The following curves in **Fig. 4** show the basic performance of the wide-band version of the 3-element Yagi.

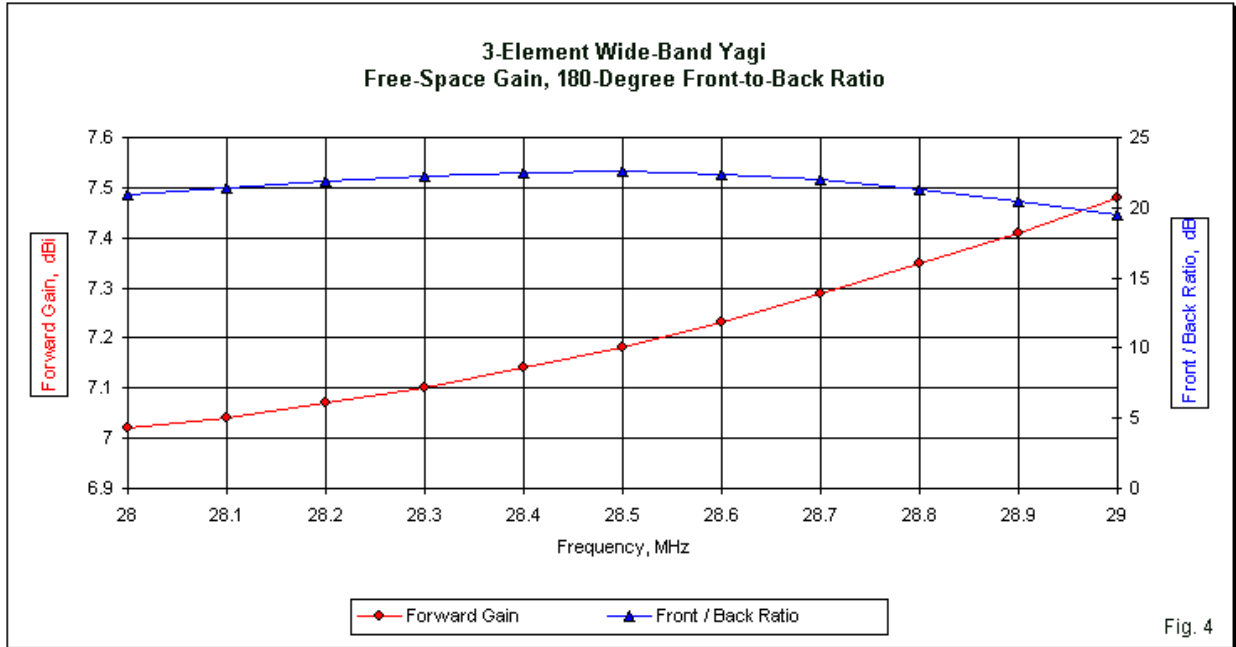

Fig. 4

As with any parasitic array with a director, the sample 3-element Yagi shows a rising gain values as the operating frequency increases. The front-to-back ratio is stable across the entire first MHz of 10 meters, dipping just below the 20-dB standard at the upper passband edge. Equally stable are the impedance and SWR curves. With a well-centered SWR curve (see **Fig. 5**), the maximum value is only about 1.4:1, even though the resistive component is slightly under 50 Ω.

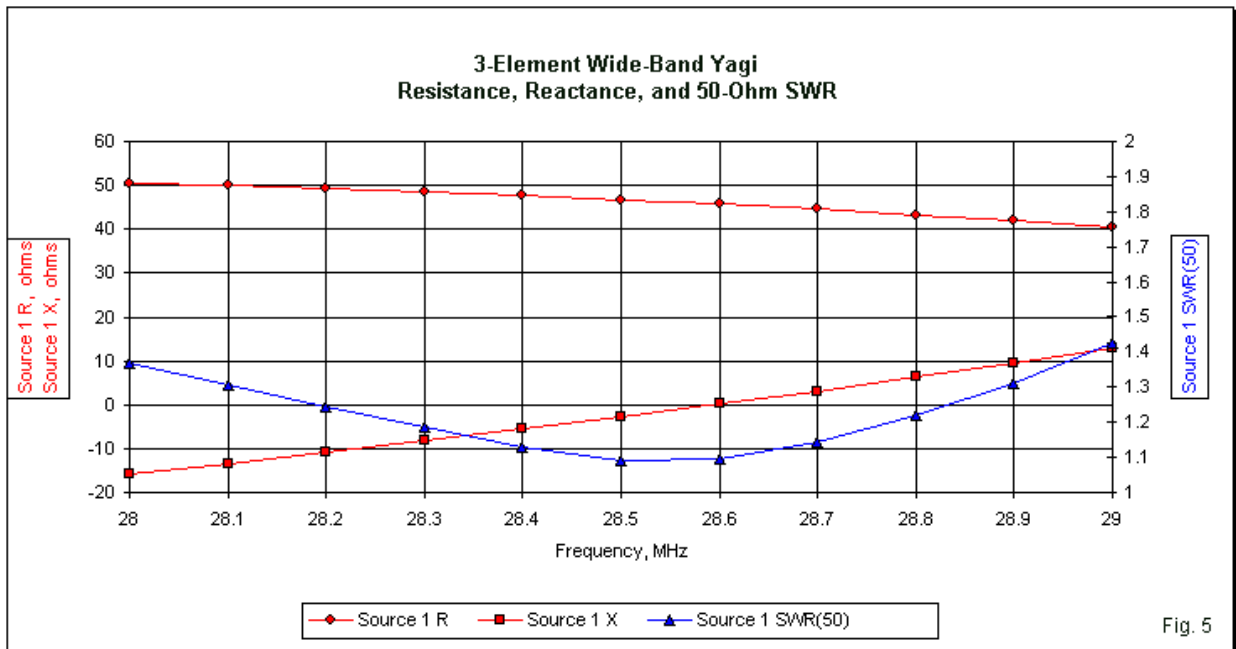

Fig. 5

The behavior of the wide-band 3-element Yagi with a wide space between the driver and the reflector suits the needs of a larger multi-band Yagi system. We often see such Yagis as the 20-meter foundation for the multi-band array. A few designs shrink the driver-to-reflector spacing to save boom length, but for a direct 50- $\Omega$  connection, the impedance of the raw 3-element Yagi rarely drops to 40  $\Omega$ .

This review of basic monoband beam performance provides us with a set of standards. When we incorporate such designs into a multi-band beam, we tend to expect a drop in performance on a given band relative to a monoband beam. This expectation does not always occur. Some facets of multi-band Yagi design can actually improve performance in one or another category, while others prove detrimental. Obviously, one fundamental principle of multi-band Yagi design is to maximize the improvements and minimize the detriments. However, learning how to do these two jobs requires that we understand what happens when we start combining elements for different bands.

### *Some Multi-Band Fundamentals*

There is no single way to create a multi-band Yagi. **Fig. 6** shows two variations on a single theme: 3 elements for 15 meters and 4 elements for 10 meters.

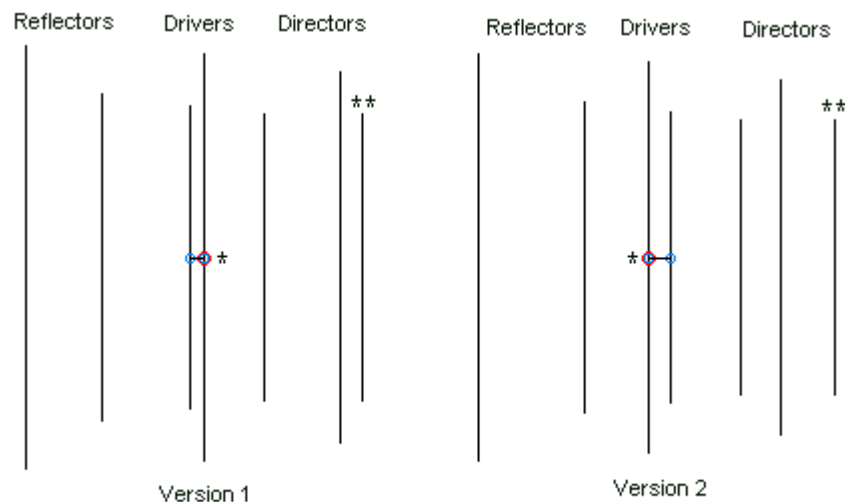

Some Basic Multi-Band Parasitic Beam Considerations

Fig. 6

The design on the left places the 10-meter or higher-frequency driver behind or on the reflector side of the 15-meter or lower frequency driver. The design on the right reverses the process. Either system has been made to work. More significant initially is the fact that the lower frequency antenna shows the proportions suited to a wide-band 3-element Yagi. However, the elements for the high-frequency Yagi have quite different spacing proportions. The differences result from mutual coupling between elements. The seemingly inactive elements for the band that is not in use are in fact quite active, even if at lower activity levels. If we use Version 1 of the multi-band Yagi outlines, we obtain different patterns of current magnitude on the various elements as we move from 15 meter to 10 meters and back again. See **Fig. 7**. The relative current magnitude values are indicators of the mutual coupling between elements, not only on the same band, but also on both bands.



Relative Current Magnitudes on the Elements of a Dual-Band Yagi at Different Frequencies

On 15 meters or the lowest band covered by the array, we may easily identify the current magnitudes associated with the 15-meter elements. The 10-meter reflector and directors show some activity, but at a low level. The activity is enough to require slight readjustments to the element lengths and spacing values on the lower band, but the changes are normally small. Hence, in most multi-band Yagi design exercises, we tend to freeze the low-band dimensions first.

When we set the higher-band elements in place, we obtain a very different situation. Although the low-band reflector is relatively inert, the low-band driver and director are very active. For both elements, note the change in the slope of the curve for the current toward the element ends. The two elements play a role in the performance on the upper band, but their greater length tends to push the performance curve into the lower portion of the upper band. Element placement and length can overcome this effect to a major degree, but the effects may limit the operating passband on the high frequencies.

The high activity of the 15-meter director also explains why most multi-band Yagis have a high-band director forward of the forward-most low-band director, as noted in the initial sketches by the double star. The added director is not in place to increase gain so much as it serves to restore control of high-band performance to the high-band element set as a whole. In some highly complex multi-band arrays, we may find a high-band director on each side of and fairly close to a low band director that can disturb the gain or impedance curves for the antenna. In many tri-band beams, the forward-most directors for 10 meter and for 20 meters seem to need the same location. Under these conditions, a designer might introduce 10-meter traps to reduce the total element count.

The activity of the elements for the band that is not in use can affect performance. Rightly used, we may enhance performance (sometimes calling this "forward stagger"). For example, the very low level activity on the 10-meter elements while 15 meters is in use can increase gain on the lower band beyond our monoband expectations for a wide-band 3-element Yagi. On the upper band, we rarely obtain all of the performance that we might expect from a 4-element monoband Yagi. However, we may show some increase above the values for a 3-element Yagi. At the same time, the intrusive mutual coupling that creates relatively high activity on the higher band has additional effects. First, it tends to make the rate of gain change across the band greater than for a monoband beam. This factor tends to make the placement and length of the upper-band elements somewhat more finicky. Very small element changes (as little as 0.5" on 10 meters) may create significant performance changes. For example, a half-inch placement change might make the difference between SWR coverage to 29.0 MHz and only



28.8 MHz, while altering the front-to-back ratio by as much as 2 dB. Murphy's law dictates that the improvement in one parameter results in a decay of the other.

Second, high activity on all elements while using the upper band may change the shape of the rearward lobes. The 15-meter director, for instance, may act to some degree like a reflector on 10 meters. The added outer director restores the forward gain, but it does not prevent an enlargement of the rearward sidelobes at some frequencies. Third, the activity of the 15-meter elements on 10 meters can create considerable change in the feedpoint impedance on the higher band.

The search for a set of element lengths and spacing values for the higher-band portion of the beam may sometimes require a revision of the lower band section to make room for elements or to change the mutual coupling between higher-band and lower-band elements. The changes may move the operating conditions of the lower-frequency portion from their most optimal monoband configuration. However, basic interactions have already modified the performance. Therefore, the goal is no longer to replicate monoband performance. Rather, the aim is for a set of operating conditions across the lower band that will be acceptable and that will allow equally acceptable performance of the upper-band elements. What counts as acceptable in the early 21<sup>st</sup> century tends to be considerably superior to performance levels of the 1970s and 1980s. Despite the efficiencies offered by computer modeling, the search for the final element settings remains a patient undertaking.

Feedpoint impedances can be a topic all unto itself. Some earlier trap-based tri-banders used network matching on 20 meters with element adjustments to arrive at adequate feedpoint impedances on higher bands. More recent trapless arrays have used one of two types of feedpoint system, both aimed at a direct connection to a 50- $\Omega$  source. One system, sometimes called open-sleeve coupling, makes a direct connection only to the driver element for the lowest band. It relies on tight mutual coupling between the fed or master driver and one or more slaved drivers for high frequency ranges. By a judicious selection of driver spacing and the length of the slaved driver, the master driver will show a 50- $\Omega$  impedance at the higher frequency, and the slaved driver will exhibit a current magnitude curve that is identical to one for a monoband driver at the same frequency. However, the position of the slaved driver relative to the array of elements will normally show a significant phase difference relative to the current at the source. Since all elements of the array will show a similar phase shift, the array operates normally. The significance of the phase shift lies in necessary steps the user must take if trying to stack beams of different types.

The second and more common feed system consists of making a direct connection between the low-band and the high-band drivers. The initial sketch of Version 1 and Version 2 of a 15-10-meter array placed a star at the feedpoints. In both cases, the direct connection to the source or feedline used the lower-frequency driver. A short parallel line connected the higher-frequency driver. Some designs reverse the connection point, running the feedline to the higher-frequency driver. It is all a matter of arriving at the correct impedance at the main feedpoint within each operating band.

Directly connected feedpoints are partially dependent upon mutual coupling between driver elements. Because directly connected drivers are usually farther apart than drivers using an open-sleeve coupling system, the coupling is weaker but still very significant. Therefore, the required length of the higher-frequency driver may differ considerably from the length of a monoband Yagi of similar design. In addition, in the higher frequency range, mutual coupling with the lower-frequency elements also results in changes in the feedpoint impedance of the

higher-frequency driver. Very often, the impedance is considerably lower than the value that the higher-frequency elements would show in isolation. The goal of the feed system is to provide the feedpoint with an acceptable impedance relative to the source—something close to 50  $\Omega$ .

The sketch of a typical direct-feed system in **Fig. 8** shows one further complexity. The lower-frequency driver presents an impedance to the feedpoint in addition to the impedance provided by the higher-frequency driver. These impedances are in parallel. The net impedance must yield the desired 50- $\Omega$  value.

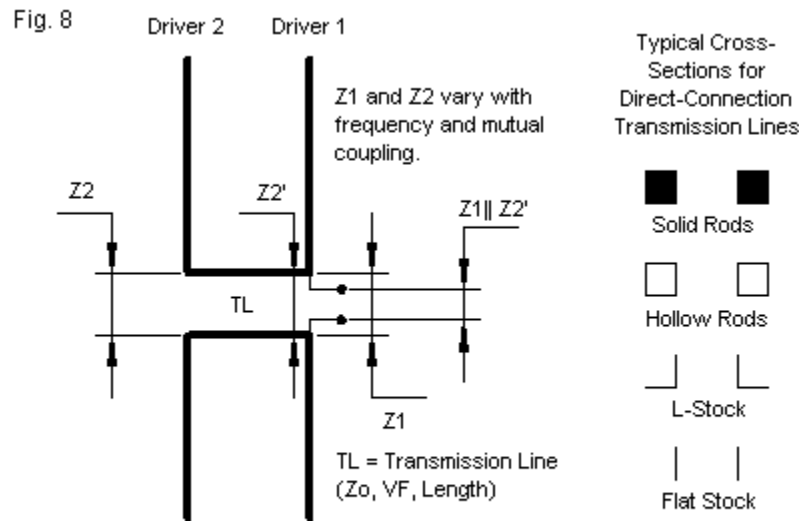

Feedpoint Considerations for Directly Connected Drivers

The direct connection lines themselves amount to a transmission line with a characteristic impedance ( $Z_0$ ), a velocity factor (VF), and a length. If the impedance designated as  $Z_2$  is 50  $\Omega$  and the line is 50  $\Omega$ , then  $Z_2'$  will also be 50  $\Omega$ . (Similar results emerge from other matched systems for the connecting line and the associated driver.) Under these conditions, if the “other” driver shows a sufficiently high impedance, the parallel combination will be about 50  $\Omega$ . At the “other” frequency, the value of  $Z_1$  would normally be close to 50  $\Omega$  and the value of  $Z_2'$  would be enough higher not to create a significant variation in that value.

Some designs manage to achieve these goals. In such cases, they require short connecting transmission lines with very low impedances. The transmission-line impedance limit for round wires is about 80  $\Omega$  before the parallel wires touch each other. Therefore, most systems using direct connection employ square conductors. Although we call them square conductors, only the surfaces facing each other play a significant role in the transmission-line properties. Therefore, as shown in the sketch, we may use a variety of materials so long as the face areas are the same. Flat-face elements are capable of  $Z_0$  values of 50  $\Omega$  or slightly lower in practical lines. Small solid rods are popular, since they are least susceptible to climate-induced shape and spacing changes.

Obtaining a  $Z_2$  value of 50  $\Omega$  when driver 2 is active is not necessary for the proper operation of a multi-band Yagi. Rather, the value of  $Z_2'$  must be close to 50  $\Omega$  and should be considerably higher when driver 1 is active. The value of  $Z_2'$  is a function of the impedance  $Z_2$  and its transformation along the length of the connecting line. The impedance transformation is



a function of the line length and the relationship of  $Z_2$  to the  $Z_0$  of the line. (Most such lines have a VF very close to 1.0.) One may experimentally try different values of  $Z_0$ , as well as different relative positions of driver 2 and its length. (Ordinarily, once close to the desired combination, the designer can make minor adjustments to the length and position of the directors to refine the value. However, all such changes may also change the gain and front-to-back performance on the higher band.) As well, one may reverse the feedline connection point to determine if a better match occurs. In fact, with drivers sufficiently far enough apart, the designer can even try reversing the connections. For some (unknown) reason, custom has dictated that reversed lines are called *phased drivers* while un-reversed lines are simply called a directly fed system. However, the principles of operation are the same: only the current phase angles at the respective connection points change.

Theoretically, we may have occasion to use any connection-line  $Z_0$  value. However, most direct connection systems employ lower values. 100 to 150  $\Omega$  is a practical upper value for such systems. If the higher-frequency system has a low impedance—commonly the case—then a very high value of  $Z_0$  may narrow the operating range of the antenna as the value of  $Z_2$  undergoes its change across the passband. The mutual coupling between lower-frequency and higher-frequency elements often creates faster rates of change in operating parameters than we would find in essentially the same high-frequency beam under monoband conditions. As well, every change in the value of  $Z_0$  may require a change in the length of driver 2, which in turn will change the value of  $Z_2$ . For some array designs, there may be no usable combination of values. At that point, the designer must revise at least the upper-band design to see if a usable combination evolves.

#### *Some Mechanical Considerations*

Some mechanical details of the proposed multi-band beam construction are arbitrary in the sense that they do not interact with the design itself. However, other facets of construction do have a direct bearing on the design. Some of these aspects of beam mechanics deserve at least brief attention.

Perhaps the most significant mechanical detail of an HF beam is the element taper schedule for each band. Rather than using long lengths of uniform-diameter tubing, virtually all HF beam elements use a series of tubes with the largest diameter at the element center and successively smaller diameter tubes farther out. The beam designer has two major responsibilities. First, he must ensure that the element can withstand a desired level of wind and ice loading. Second, he must take the element taper schedule into account in the design process.

An element that tapers from the center outward will be longer for resonance on any given frequency than one that is a uniform diameter, even if the uniform diameter is below the average diameter of the tapered element. Associated with the element taper are a number of modeling issues that we shall note separately. In this section, we need to note that every variation in the taper schedule will result in required element length changes. Even elements that use the same set of tubing diameters will yield different element lengths if the lengths of the individual subsections of the element differ. See Chapter 8 of the *Physical Design of Yagi Antennas* by David Leeson, W6NL, for a detailed analysis of tapered elements and their uniform-diameter equivalents.

In general, the beam designer should choose an element taper in advance based on the desired wind-load survivability that he wishes to assign to the antenna. In part, this decision rests on the materials selected for the array. In Europe, where metric aluminum tubing sizes

are available, most designers use aluminum with thicker walls than we commonly use in the U.S. The resultant beams, like European oaks, tend to be heavier assemblies, but may be close to indestructible. In contrast, some U.S. makers have used thinner-wall materials. With proper selection, the elements are just as capable of withstanding heavy winds and ice loading, but they tend to flex like the branches of willows.

In the middle is the U.S. standard tubing material: 6062-T832 aluminum with a standard wall thickness of about 0.056" (sometimes given as 0.058"). The hard aluminum material is available in 0.125" increments. The difference between the seemingly ideal wall thickness of 0.0625" and 0.056" allows for manufacturing tolerances while still providing a smooth but close fit between tubing sizes. By properly selecting the lengths of the fatter sections, we can arrive at a very strong element for any upper HF band.

We may approach the element-tapering schedule in two different ways. The most fundamental method is to use a program like *YagiStress* to design the element from scratch. Equally effective is to use tapering schedules that have already undergone such design work. For example, Dean Straw, N6BV designed both the physical and electrical properties of the monoband Yagis shown in Chapter 11 any recent edition of *The ARRL Antenna Book*. For our exercises that involve 15-meter and 10-meter elements, we might replicate one of the two schedules that he uses. **Fig. 9** shows the relevant dimensions of the heavy-duty schedule that can withstand winds well above 100 miles per hours, with appropriate de-rating for ice loads.

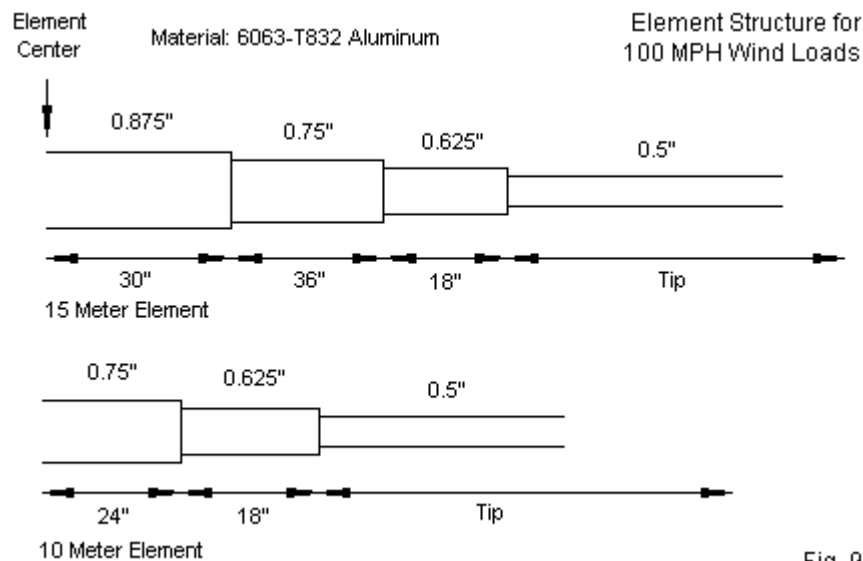

The sketches show half elements. The 0.5" diameter tip sections are open ended, since the length of that section will vary from one element to the next. However, the tip section can be any reasonable length for an element on the selected band and still maintain the wind-load rating. Each section shows the exposed length of tubing. An overlap of from 2 to 3 additional inches is normally sufficient to ensure good section-to-section electrical contact and a secure connection using common fasteners, such as stainless steel sheet-metal screws.

The design dimensions will also depend to some degree on the construction method to be used, especially with respect to the element-to-boom mounting technique. The direct-connection feedpoint system that we have discussed requires that the driver elements be well

insulated and isolated from any conductive boom material. The parasitic elements may use a similar mounting system or be directly connected to the boom. Directly connected elements will require a length adjustment—usually longer—than elements that emerge from computer software such as NEC.

For uniformity, I personally tend to prefer the use of isolated elements, although that preference is by no means universal. **Fig. 10** shows the details of the element-to-boom assembly that I have used on several monoband and multi-band beams.

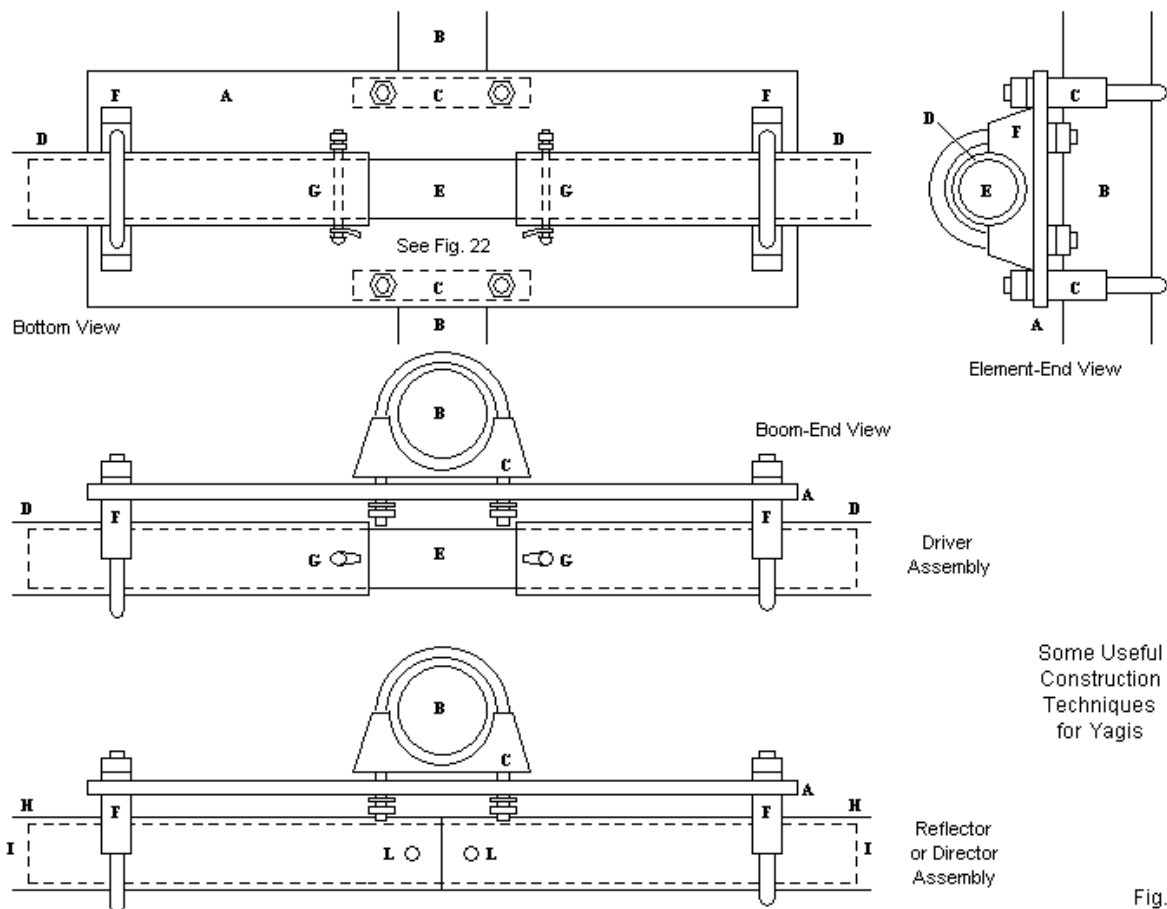

Fig. 10

The keys to the element in the sketch follow:

- A Polycarbonate element-to-boom mounting plate
- B Boom
- C Boom stainless-steel U-bolts and saddles
- D Driven element tube
- E Driven element gap insulating rod or tube
- F Element stainless-steel U-bolts and saddles
- G Stainless-steel nuts/bolts/washers/soldering lugs
- H Reflector or director element tubes
- I Inner linking conductive tube
- J L-stock coax connector mounting plate
- K Through-chassis coax connector
- L Stainless-steel sheet-metal screws

The elements require a linking piece at the center. The parasitic elements (reflectors or directors) require a scrap of conductive tubing (I), while the driven element requires an insulating material, such a fiberglass rod (E). The linking pieces extend just beyond the outer U-bolts to allow element alignment with only two U-bolt fasteners. The driver gap size is not especially critical in the upper HF region, but should be as small as good electrical separation and easy connection assembly permit. The gap is a part of the overall element length, not an addition to it.

All hardware should be stainless steel. This requirement applies to U-bolts (C and F), nut-bolt-washer combinations (G), and sheet metal screws (L). Stainless steel serves two purposes. First, it resists corrosion across the range of weather conditions we are likely to experience in the U.S. Second, it is not subject to electrolysis, which can occur when dissimilar metals join. Therefore, use washers liberally at the connection of copper conductors to the aluminum driven element. The U-bolts show solid aluminum saddles, which are less subject to element compression than double-edge muffler-clamp types of saddles. I do not recommend U-bolts without saddles. I do recommend flat washers between U-bolt lock washers and the mounting plates to avoid gouging the plate and loosening the connection.

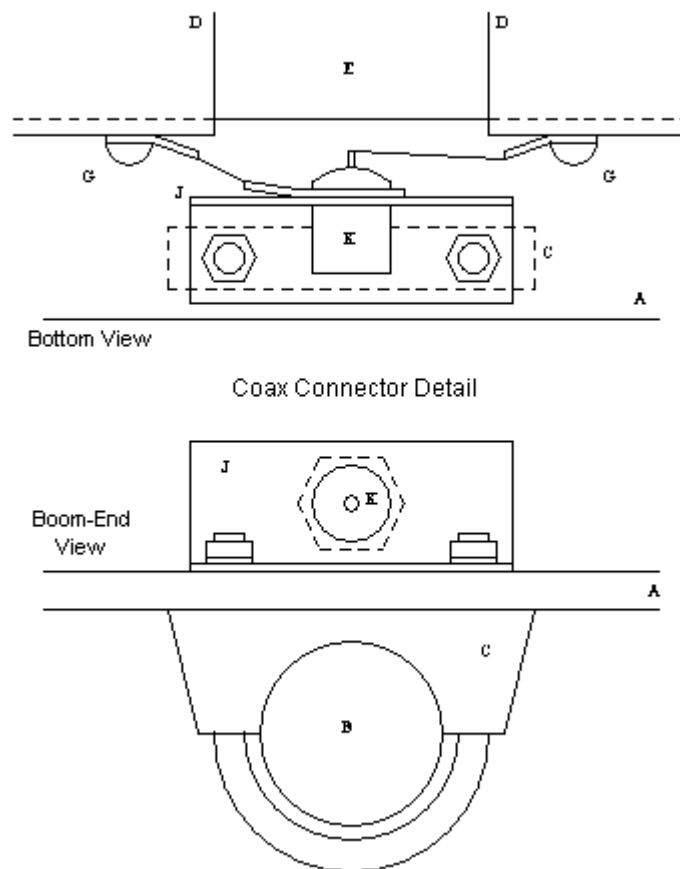

Fig. 11

**Fig. 11** shows one way to install a coax connector (K) to the driven element. The through-chassis connector will fit neatly in the space provided by aluminum L-stock with 1" wide walls and 1/16" thickness. The mounting plate L-stock (J) can extend between two boom U-bolt ends

for secure fastening. The connector end of the coax fixture should face the mast position along the boom.

The basic plates that I prefer are polycarbonate, sold under the trade name Lexan in some places. The plate size will vary with the amateur band, which generally determines element size and weight. 1/4" thick material generally satisfies most upper HF requirements. The material should be UV-protected. Like Plexiglas, it cuts and drills like wood, in contrast to the acrylic materials available in many home centers. In conjunction with the non-conductive polycarbonate plates, the U-bolt saddles insure satisfactory separation between the element and the boom to attenuate potential interactions to a negligible level.

Many alternative construction techniques are available and can be equally satisfactory. The techniques shown simply coincide with the design decision to use elements that are universally insulated and isolated from the boom. This decision also coincides with the principal design techniques, which involve the use of NEC or MININEC software.

### *Modeling Considerations*

We have already seen some of the fruits of using NEC software as a design tool for creating multi-band beams. Although the graphic portrayals of radiation patterns and performance curves have resulted from EZNEC Pro/4, similar outputs are available from other implementations of NEC. However, not all NEC cores are equal.

The public domain version of NEC (-2) cannot model linear elements with stepped-diameter elements without significant error, due to the simplified current algorithm used by that early (1980) core. In NEC-4, program developers increased the complexity of the current calculations and improved the accuracy of the core relative to linear elements having a variable diameter. However, even NEC-4's accuracy suffers if the steps between element diameters are too great. The normal 0.125" increments used in standard U.S. element construction does not stress the program limits in this regard.

NEC-2 is usable for multi-band (or monoband) Yagi design and analysis in the upper HF region if the implementation provides the Leeson corrections. As earlier noted, Leeson used the work of Schelkunoff to develop calculations for creating a uniform-diameter substitute element that had the same properties as a specified stepped-diameter element. NEC programs that allow this correction perform calculations using the substitute element and not the original element structure specified by the user in the wire entry portion of the program. Empirical tests have shown the corrections to be highly accurate when used within their limitations. The corrections are applicable only within a frequency range of about +/-15% of the frequency at which the substitute element is 1/2-λ long. As well, the element must have no loads to disturb the normal current distribution along the length.

**Fig. 12** shows two 15-meter elements from one test array, along with the Leeson re-calculations. The substitute uniform-diameter elements are both significantly shorter than the specified tapered-diameter element with the same performance. In addition, both sample elements use the same element taper schedule and differ only in the tip length. Note that as the overall length of the element grows shorter under these conditions, the re-calculated uniform diameter grows fatter. The substitute element as a NEC model consists of the same number of individual wires per element, and each substitute wire has the same number of segments as the original section that it replaces.

Wires											
Wire Create Edit Other 2 Stepped-Diameter 15-Meter Elements											Fig. 12
<input type="checkbox"/> Coord Entry Mode <input type="checkbox"/> Preserve Connections											<input type="checkbox"/> Show Wire Insulation
Wires											
No.	End 1				End 2				Diameter (in)	Segs	
	X (in)	Y (in)	Z (in)	Conn	X (in)	Y (in)	Z (in)	Conn			
1	0	143	0		0	84	0	W2E1	0.5	6	
2	0	84	0	W1E2	0	66	0	W3E1	0.625	2	
3	0	66	0	W2E2	0	30	0	W4E1	0.75	3	
4	0	30	0	W3E2	0	-30	0	W5E1	0.875	7	
5	0	-30	0	W4E2	0	-66	0	W6E1	0.75	3	
6	0	-66	0	W5E2	0	-84	0	W7E1	0.625	2	
7	0	-84	0	W6E2	0	-143	0		0.5	6	
8	120	137	0		120	84	0	W9E1	0.5	5	
9	120	84	0	W8E2	120	66	0	W10E1	0.625	2	
10	120	66	0	W9E2	120	30	0	W11E1	0.75	3	
11	120	30	0	W10E2	120	-30	0	W12E1	0.875	7	
12	120	-30	0	W11E2	120	-66	0	W13E1	0.75	3	
13	120	-66	0	W12E2	120	-84	0	W14E1	0.625	2	
14	120	-84	0	W13E2	120	-137	0		0.5	5	

Stepped Diameter Correction											
Edit Other Uniform-Diameter Equivalents of 2 Stepped-Diameter 15-Meter Elements											
Wires											
No.	End 1				End 2				Diameter (in)	Segs	
	X (in)	Y (in)	Z (in)	Conn	X (in)	Y (in)	Z (in)	Conn			
1	0	138.862	0		0	81.5693	0	W2E1	0.65755	6	
2	0	81.5693	0	W1E2	0	64.0902	0	W3E1	0.65755	2	
3	0	64.0902	0	W2E2	0	29.1319	0	W4E1	0.65755	3	
4	0	29.1319	0	W3E2	0	-29.1319	0	W5E1	0.65755	7	
5	0	-29.1319	0	W4E2	0	-64.0902	0	W6E1	0.65755	3	
6	0	-64.0902	0	W5E2	0	-81.5693	0	W7E1	0.65755	2	
7	0	-81.5693	0	W6E2	0	-138.862	0		0.65755	6	
8	120	133.005	0		120	81.5505	0	W9E1	0.66702	5	
9	120	81.5505	0	W8E2	120	64.0754	0	W10E1	0.66702	2	
10	120	64.0754	0	W9E2	120	29.1252	0	W11E1	0.66702	3	
11	120	29.1252	0	W10E2	120	-29.1252	0	W12E1	0.66702	7	
12	120	-29.1252	0	W11E2	120	-64.0754	0	W13E1	0.66702	3	
13	120	-64.0754	0	W12E2	120	-81.5505	0	W14E1	0.66702	2	
14	120	-81.5505	0	W13E2	120	-133.005	0		0.66702	5	

Just as it is possible to press NEC-4 toward inaccuracy by making the diameter steps too large, we may also stress the accuracy of substitute elements by failing to attend closely to the segmentation. NEC is most accurate when all segments in a simple or complex wire are the same length. The need for this measure is greatest in the high-current region of the element, that is, at the element center region for standard Yagi designs. Violation of this recommendation tends to yield plausible results that simply do not set the operating parameters on the desired frequency in a physical implementation of the antenna.

NEC's calculations involve only axial currents, that is, currents along the length of a wire. The program does not calculate transverse currents. For elements that are well insulated and isolated from a conductive boom, this limitation presents no difficulties. However, for elements



connected to a conductive boom, the program does not take into account the effects of the boom of the required element length for a given set of performance specifications, such as self-resonance. One effective technique to compensate for this situation is the insertion of a very short but very fat element section at the center of the element. For the element taper shown, when intended for direct contact with the boom, one might insert a 6" section of 3.0" diameter wire on 15 meters and a similar section of 2.8" wire on the 10-meter element. The technique carries with it a difficulty. For parasitic elements, the length of the inserted section, if 1 segment long, determines the length of all other segments in the element. A multi-band beam with many elements can easily grow quite large in terms of the total segment count. More significantly, if the segment lengths are not as equal as the model permits, the calculations based on the Leeson substitute elements may also become less accurate.

### *Conclusion to Part 1*

These notes have tried to coalesce the main lines of challenges facing anyone who may wish to design a multi-band Yagi. The individual challenges included developing reasonable expectations, accounting for the many forms of element interaction, deciding upon the element structure, and using design software within its limitations. All of these factors interact in the design process. As a result, there can be no final comprehensive treatment of the process. As much as an understanding of the principles of antenna element interaction undergirds the process of creating an effective multi-band Yagi, there remains an element of artistry that deserves admiration.

In Part 2, we shall put some of the considerations explored here to the test. We shall look at a small beam for 15 and 10 meters. It will be relatively simple, involving only 2 elements per band. However, the 15-meter parasitic beam will not be a true Yagi, but instead a Moxon rectangle. In later sections, we shall examine a more complex Yagi combination that will use 3-elements on 15 meters and at least 4 elements on 10 meters to form a relatively high performance 2-band Yagi. Both types of beams will reveal how we may use element interactions to enhance performance, as well as the decisions we might face in accepting one or another limitation.

**© All Rights Reserved World Wide  
ANTENNEX LLC**